



METER

ATMOS 22 GEN 2



TABLE OF CONTENTS

1. Introduction	1
2. Operation	2
2.1 Installation	2
2.2 Connecting	4
2.2.1 Connect to METER Data Logger	5
2.2.2 Connect to Non-METER Logger	5
2.3 Communication	7
2.3.1 SDI-12	7
2.3.2 Modbus RTU	7
3. System	8
3.1 Specifications	8
3.2 Anemometer	11
3.3 Temperature Sensor	12
3.4 Tilt Sensor	13
3.5 Wind Speed and Direction Theory	13
3.6 Limitations	15
3.6.1 Snow and Ice Accumulation	15
3.6.2 Heavy Rain and Strong Wind	15
3.7 Measurements with METER Data Loggers	15
4. Service	17
4.1 Calibration	17
4.2 Cleaning and Maintenance	17

4.3 Troubleshooting.....	18
4.4 Customer Support.....	19
4.5 Terms and Conditions	19
Reference	20
Index	21

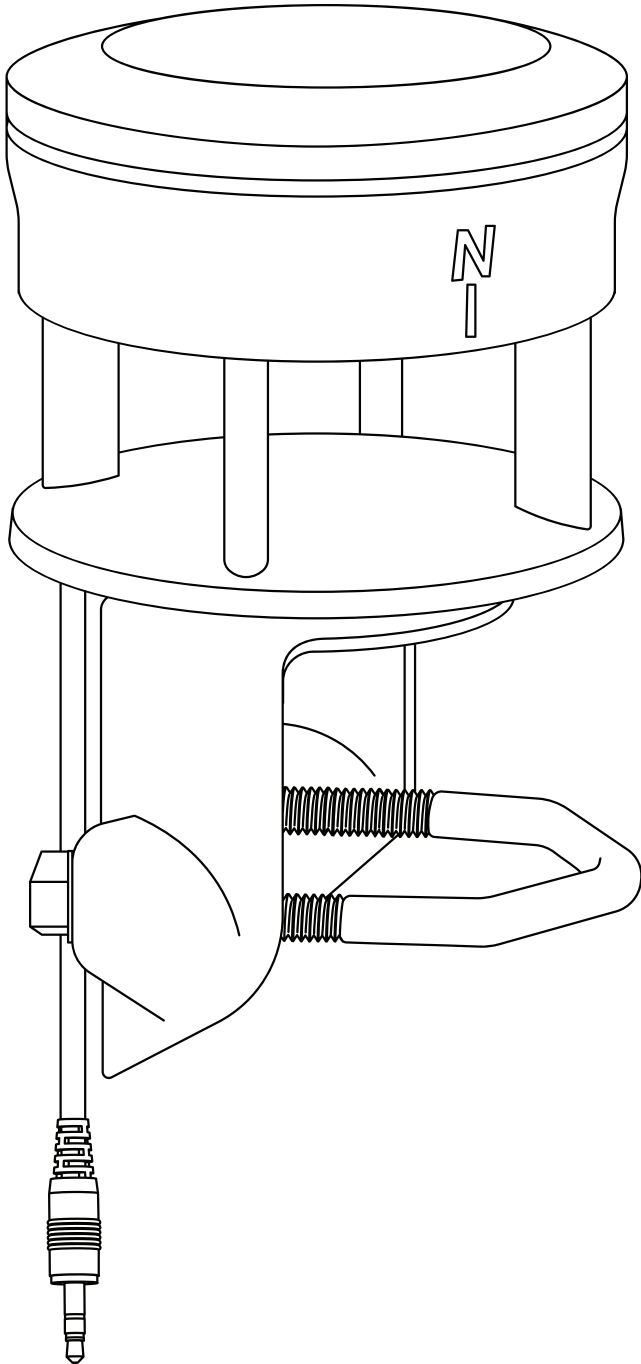

1. INTRODUCTION

Thank you for choosing the ATMOS 22 GEN 2 Ultrasonic Anemometer from METER Group.

The ATMOS 22 GEN 2 Ultrasonic Anemometer is designed for continuous monitoring of wind speed and direction ([Section 3](#)). A robust, no moving parts design that prevents errors because of wear or fouling make the ATMOS 22 GEN 2 ideal for long-term, remote installations.

Applications of the ATMOS 22 GEN 2 are listed below:

- Weather monitoring
- Microenvironment monitoring
- In-canopy wind measurement
- Spatially-distributed environmental monitoring
- Wind profiling
- Crop weather monitoring
- Weather networks

Additional advantages include its low-power design that supports battery-operated data loggers, the SDI-12 three-wire interface, and some models are Modbus RTU enabled. A tilt sensor warns the user of out-of-level condition, and no configurations are necessary.

Prior to use, verify the ATMOS 22 GEN 2 arrived in good condition.

2. OPERATION

Please read all instructions before operating the ATMOS 22 GEN 2 to ensure it performs to its full potential.

PRECAUTION

METER sensors are built to the highest standards, but misuse, improper protection, or improper installation may damage the sensor and possibly void the manufacturer's warranty. Before integrating ATMOS 22 GEN 2 into a system, make sure to follow the recommended installation instructions and have the proper protections in place to safeguard sensors from damage.

2.1 INSTALLATION

Follow the steps listed in [Table 1](#) to set up the ATMOS 22 GEN 2 and start collecting data.

Table 1 Installation

Tools Needed	<p>Wrench double-sided 8-mm and 13-mm (1/3 and 1/2 in)</p> <p>Mounting pole 31.8 to 50.8 mm (1.25 to 2.0 in) diameter</p> <p>NOTE: Smaller mounts are compatible if washers are added to the V-bolt (not included). United States standard pipe sizes that are compatible are 1.00-, 1.25-, and 1.50-in. Square tubing with a width of 1.25 to 2.00 in or T-posts can also work as mounting options.</p>
	<p>Consider the Surroundings Ensure that site selection is far from wind obstruction.</p> <p>Conduct System Check Plug the weather station into the logger (Section 2.2).</p> <p>Preparation Verify all sensors are functional and read within expected ranges.</p> <p>Adjust Pole Height Prepare the mounting pole to the appropriate height. Many installations require the ATMOS 22 GEN 2 to be mounted 2 m above ground, but mounting height can be adjusted based on the specific application.</p>

Mounting

Install on Mounting Pole

Use the V-bolt to secure the unit to the mounting pole. The V-bolt is compatible with most meteorological stands, poles, tripods, and other mounts.

Place the top of the post under the ATMOS 22 mounting shelf.

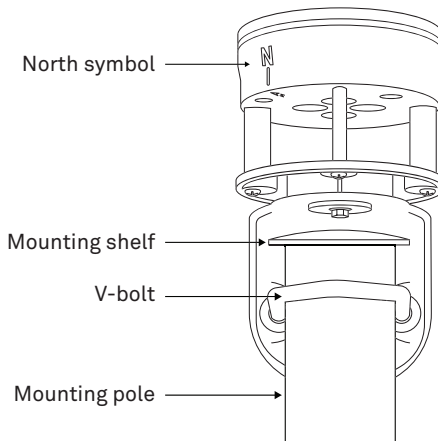
**Secure the System**

Tighten the V-bolt nuts by hand until hand-tight, and then tighten with a wrench, securing the ATMOS 22 GEN 2 flat and tight against the top of the stand.

CAUTION: Do not overtighten V-bolt.

Mount Toward True North

Orient the **N** on the side of the instrument to point true north (not magnetic north). The ATMOS 22 GEN 2 must be oriented correctly by hand for accurate wind direction measurements.

Level the System

Use the bubble level underneath the ATMOS 22 GEN 2 to level the weather station. The weather station angle can be adjusted by loosening the leveling screw attached to the bottom with the 8-mm wrench (included). Once the leveling screw is loose, move the weather station side to side as needed to level and then retighten the screw.

CAUTION: Do not overtighten screw.

The angle of the mounting pole may also need to be adjusted to achieve level.

Table 1 Installation (continued)**Mounting
(continued)****Secure and Protect Cables**

NOTE: Improperly protected cables can lead to severed cables or disconnected sensors. Cabling issues can be caused by many factors such as rodent damage, driving over sensor cables, tripping over cables, not leaving enough cable slack during installation, or poor sensor wiring connections.

Install cables in conduit or plastic cladding when near the ground to avoid rodent damage.

Gather and secure cables between the ATMOS 22 GEN 2 and the data logger to the mounting mast in one or more places.

Connect to Data Logger

Plug the sensor into a data logger.

Use the data logger to make sure the sensor is reading properly.

Verify these readings are within expected ranges.

For more instructions on connecting to data loggers, refer to [Section 2.2](#).

2.2 CONNECTING

The ATMOS 22 GEN 2 works seamlessly with METER data loggers. The ATMOS 22 GEN 2 can also be used with other data loggers, such as those from Campbell Scientific, Inc. For extensive directions on how to integrate the sensor into third-party loggers, refer to the [ATMOS 22 Integrator Guide](#) (meter.ly/atmos22-g2-ig).

ATMOS 22 GEN 2 sensors require excitation voltages in the range of 3.6 to 25.0 VDC and operates at 2.8- to 5.5-VDC level for data communication.

The ATMOS 22 GEN 2 can be integrated using SDI-12 protocol or Modbus RTU in enabled units. See the [ATMOS 22 Integrator Guide](#) for details on interfacing with data acquisition systems.

ATMOS 22 GEN 2 sensors come with a 3.5-mm stereo plug connector ([Figure 1](#)) to facilitate easy connection with METER loggers. ATMOS 22 GEN 2 sensors may be ordered with stripped and tinned wires to facilitate connecting to some third-party loggers ([Section 2.2.2](#)).

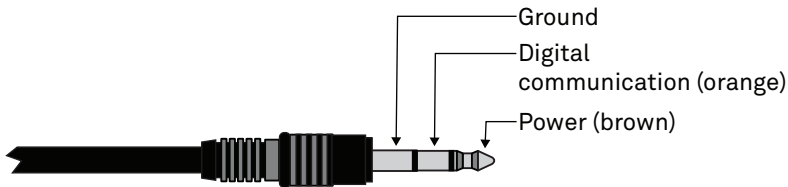
**Figure 1 3.5-mm stereo plug connector wiring**

The ATMOS 22 GEN 2 comes standard with a 5-m cable. It may be purchased with custom cable lengths for an additional fee (on a per-meter basis). In some instances, the cable can be extended beyond 75 m by the user, but this is discouraged for a variety of reasons. Please contact [Customer Support](#) for more details before extending or splicing cables.

2.2.1 CONNECT TO METER DATA LOGGER

The ATMOS 22 GEN 2 works most efficiently with ZENTRA series data loggers. Check the METER [downloads webpage](https://meter.ly/download-support) (meter.ly/download-support) for the most recent data logger firmware. Logger configuration may be done using either ZENTRA Utility (desktop and mobile application) or ZENTRA Cloud (web-based application for cell-enabled data loggers).

NOTE: This system will not work with legacy data loggers (Decagon Em5 or Em5B).

1. Plug the stereo plug connector into one of the sensor ports on the logger.
2. Use the appropriate software application to configure the chosen logger port for the ATMOS 22 GEN 2. METER data loggers will automatically recognize ATMOS 22 GEN 2 sensors.
3. Set the measurement interval.

METER data loggers measure the ATMOS 22 GEN 2 every minute and return the average of the 1-min data across the chosen measurement interval. For example, the interval can be set to 5 min, 10 min, 15 min. See [Table 2](#) for additional information.

ATMOS 22 GEN 2 data can be downloaded from METER data loggers using either ZENTRA Utility or ZENTRA Cloud. Refer to the logger user manual for more information about these programs.

2.2.2 CONNECT TO NON-METER LOGGER

The ATMOS 22 GEN 2 can be purchased for use with non-METER (third party) data loggers. Refer to the third-party logger manual for details on logger communications, power supply, and ground ports. The [ATMOS 22 Integrator Guide](#) also provides detailed instructions on connecting sensors to non-METER loggers.

ATMOS 22 GEN 2 sensors can be ordered with stripped and tinned (pigtail) wires for use with screw terminals. Refer to the third-party logger manual for details on wiring.

Connect the ATMOS 22 GEN 2 wires to the data logger as illustrated in [Figure 2](#) and [Figure 3](#), with the power supply wire (brown) connected to the excitation, the digital out wire (orange) to a digital input, and the bare ground wire to ground.

OPERATION

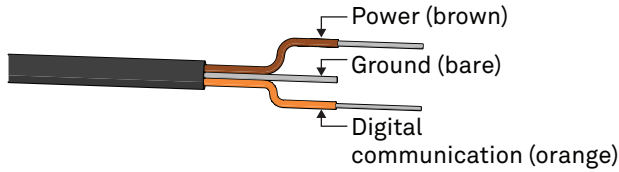

Figure 2 Pigtail wiring

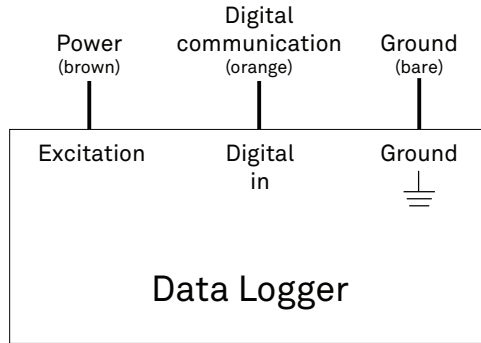

Figure 3 Wiring diagram

NOTE: The acceptable range of excitation voltages is from 3.6 to 25.0 VDC. To read the ATMOS 22 GEN 2 with Campbell Scientific data loggers, power the sensors off a 12-V port (or any port that continuously powers from 3.6–25.0 VDC).

If the ATMOS 22 GEN 2 cable has a standard stereo plug connector and needs to be connected to a non-METER data logger, use one of the following two options.

Option 1

1. Clip off the stereo plug connector on the sensor cable.
2. Strip and tin the wires.
3. Wire it directly into the data logger.

This option has the advantage of creating a direct connection and minimizes the chance of the sensor becoming unplugged. However, it then cannot be easily used in the future with a METER readout unit or data logger.

Option 2

Obtain an adapter cable from METER.

The adapter cable has a connector for the stereo plug connector on one end and three wires (or pigtail adapter) for connection to a data logger on the other end. The stripped and tinned adapter cable wires have the same termination as in [Figure 3](#): the brown wire is excitation, the orange is output, and the bare wire is ground.

NOTE: Secure the stereo plug connector to the pigtail adapter connections using adhesive-lined heat shrink to ensure the sensor does not become disconnected during use.

2.3 COMMUNICATION

The ATMOS 22 GEN 2 can communicate using SDI-12 protocol or Modbus RTU.

2.3.1 SDI-12

The SDI-12 protocol requires that all sensors have a unique address. ATMOS 22 GEN 2 sensor factory default is an SDI-12 address of 0. To add more than one SDI-12 sensor to a bus, the sensor address can be changed using a ZSC Bluetooth® sensor interface and the ZENTRA Utility Mobile app as described below:

NOTE: The sensor SDI-12 address must be returned to 0 to work with ZENTRA loggers.

1. Using a mobile device, open the ZENTRA Utility Mobile app.
2. Connect the sensor to the ZSC.
3. Under Sensor Information, select the SDI Address dropdown.
4. Scroll through the options and select the desired SDI-12 address.

NOTE: Address options include 0-9, A-Z, and a-z.

Detailed information can also be found in the application note [Setting SDI-12 addresses on METER digital sensors using Campbell Scientific data loggers and LoggerNet](#).

When using the sensor as part of an SDI-12 bus, excite the sensors continuously to avoid issues with initial sensor startup interfering with the SDI-12 communications.

2.3.2 MODBUS RTU

ATMOS 22 GEN 2 sensors communicate using the Modbus RTU protocol. Modbus RTU protocol requires that all devices on the bus have a unique address. The ATMOS 22 Gen 2 sensor factory default is a Modbus RTU address of 1.

Detailed information on changing the Modbus RTU address can be found in the ATMOS 22 Gen 2 Integrator Guide. Details on Modbus data registers can also be found in the Integrator's Guide.

3. SYSTEM

This section describes the ATMOS 22 GEN 2 Ultrasonic Anemometer.

3.1 SPECIFICATIONS

MEASUREMENT SPECIFICATIONS

Horizontal Wind Speed

Range	0–60 m/s
Resolution	0.01 m/s
Accuracy	The greater of 0.3 m/s or 6% of measurement

Wind Gust

Range	0–60 m/s
Resolution	0.01 m/s
Accuracy	The greater of 0.3 m/s or 6% of measurement

Wind Direction

Range	0°–359.9°
Resolution	0.1°
Accuracy	±5°

Tilt

Range	–90° to 90°
Resolution	0.1°
Accuracy	±1°

COMMUNICATION SPECIFICATIONS

Output

SDI-12 communication or Modbus RTU (on enabled units)

Data Logger Compatibility

METER ZL6 and EM60 data loggers or any data acquisition systems capable of 3.6- to 25.0-VDC excitation and SDI-12 communication

PHYSICAL SPECIFICATIONS

Dimensions

Diameter	10.16 cm (4.00 in)
Height	18.28 cm (7.20 in)

Operating Temperature Range

Minimum	-50 °C
Typical	NA
Maximum	60 °C

Cable Length

- 5 m (stereo plug)
- 1.5 m (5-pin)
- 75 m (maximum custom cable length for additional cost)

NOTE: Contact [Customer Support](#) if a nonstandard cable length is needed.

Cable Diameter

0.165 ±0.004 in (4.20 ±0.10 mm), with minimum jacket of 0.030 in (0.76 mm)

Connector Types

- Stereo plug connector or 3 stripped and tinned wires
- 5-pin M12 connector or 4 stripped and tinned wires

Connector Diameter

- 3.5 mm (diameter stereo plug)
- 14.4 mm (diameter M12)

Conductor Gauge

22-AWG / 24-AWG drain wire

ELECTRICAL AND TIMING CHARACTERISTICS

Supply Voltage (VCC to GND)

Minimum	3.6 VDC continuous
Typical	NA
Maximum	25.0 VDC continuous

NOTE: The ATMOS 22 GEN 2 must be continuously powered to work properly.

NOTE: For the ATMOS 22 GEN 2 to meet digital logic levels specified by SDI-12, it must be excited at 3.9 VDC or greater.

Digital Input Voltage (logic high)

Minimum	2.8 V
Typical	3.6 V
Maximum	5.0 V

Digital Input Voltage (logic low)

Minimum	-0.3 V
Typical	0.0 V
Maximum	0.8 V

Digital Output Voltage (logic high)

Minimum	NA
Typical	3.6 V
Maximum	NA

NOTE: For the ATMOS 22 GEN 2 to meet digital logic levels specified by SDI-12, it must be excited at 3.9 VDC or greater.

Power Line Slew Rate

Minimum	1.0 V/ms
Typical	NA
Maximum	NA

Current Drain (during measurement)

Minimum	0.2 mA
Typical	8.0 mA
Maximum	33.0 mA

Current Drain (while asleep)

Minimum	0.2 mA
Typical	0.3 mA
Maximum	0.4 mA

Current Drain (while asleep, Modbus enabled)

Minimum	2.0 mA
Typical	2.5 mA
Maximum	3.5 mA

Power Up Time (SDI ready)—aRx! Commands

Minimum	NA
Typical	5 s
Maximum	NA

Power Up Time (SDI ready)—Other Commands

Minimum	NA
Typical	130 ms
Maximum	NA

Power Up Time (SDI-12, DDI disabled)

Minimum	NA
Typical	200 ms
Maximum	NA

Measurement Duration

Minimum	NA
Typical	110 ms
Maximum	3,000 ms

COMPLIANCE

EM ISO/IEC 17050:2010 (CE Mark)

3.2 ANEMOMETER

The open space in the center of the anemometer is where the ATMOS 22 GEN 2 measures wind speed. Ultrasonic signals emitted from transducers orthogonal to each other bounce off the convex base plate ([Figure 4](#)) and back up to the opposite sensor. The speed of sound is affected by the wind, and the wind speed is calculated by measuring differences in the time it takes for sound to travel back and forth between sensors ([Section 3.5](#)).

When powered on, the ATMOS 22 GEN 2 measures the wind speed and direction once every 3 s and records the instantaneous wind vector components. When queried, the ATMOS 22 outputs the average of the instantaneous measurements since the last query for wind speed and direction and the maximum instantaneous wind speed value for wind gust.

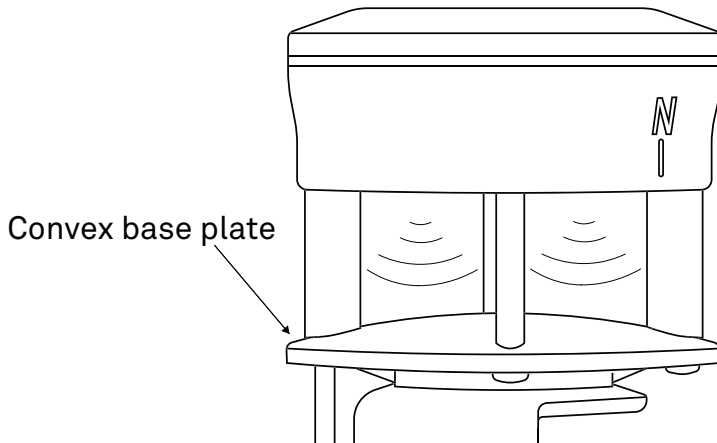

Figure 4 Anemometer

The ATMOS 22 GEN 2 measures wind speed every 3 s and keeps a running average of the last 10 measurements. If an instantaneous measurement is more than eight times the running average, the instantaneous measurement is rejected. It is not reported as the maximum gust or included in the data that are averaged over the output interval.

For normal ATMOS 22 GEN 2 use cases, this is an effective method for eliminating inaccuracy resulting from spurious spikes in wind speed (e.g., bumblebee checking out the ultrasonic path). In special use cases where data are output frequently and large step changes in wind speed are present (e.g., turning on a wind tunnel), this spike rejection algorithm may result in an error code being output.

3.3 TEMPERATURE SENSOR

The ATMOS 22 GEN 2 temperature measurement (Figure 5) is made in the small stainless steel needle containing a tiny temperature sensor (thermistor) that extends from the middle of the four ultrasonic transducers in the center of the anemometer. The speed of sound is temperature dependent, so the ATMOS 22 GEN 2 temperature measurement is important for the wind speed and direction calculations. The ATMOS 22 GEN 2 temperature measurement should not be used as an accurate measurement of air temperature. Testing has shown errors of as much as 2 °C between the ATMOS 22 GEN 2 temperature sensor and the true air temperature under sunny conditions.

When powered on, the ATMOS 22 GEN 2 measures the air temperature once every 3 s and records the instantaneous values. When queried, the ATMOS 22 GEN 2 outputs the average of the instantaneous measurements since the last query.

NOTE: Temperature data will not be collected by legacy Em50 series data loggers.

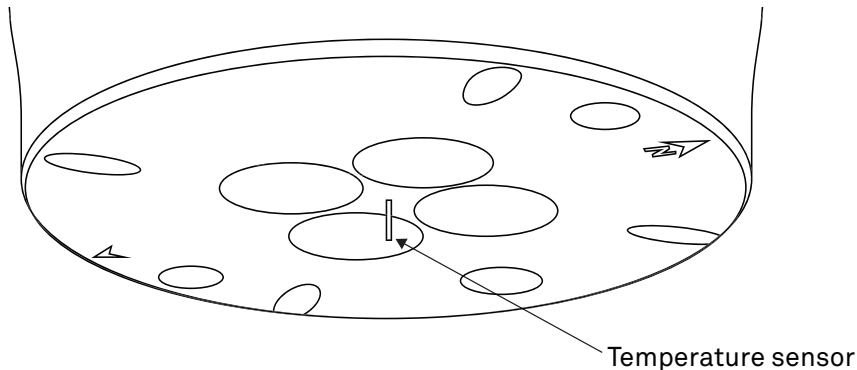

Figure 5 Temperature sensor

3.4 TILT SENSOR

The ATMOS 22 GEN 2 is also equipped with a tilt sensor similar to those found in smartphones. The primary use of the tilt sensor data is to ensure the ATMOS 22 GEN 2 remains level at all times. Regularly check X and Y tilt data to ensure the ATMOS 22 GEN 2 is level; if it has tilted, return to the site and level again. Although this sensor may also be used to level the instrument during installation, it is much easier to use the small bubble level on the bottom of the anemometer plate. For reference, a positive X tilt indicates that the ATMOS 22 GEN 2 is leaning north, and a positive Y tilt indicates that the ATMOS 22 GEN 2 is leaning west.

NOTE: Tilt data will not be collected by legacy Em50 series data loggers.

3.5 WIND SPEED AND DIRECTION THEORY

The theory behind the anemometer comes from Campbell and Unsworth (1979). The speed c (m/s) of sound in still air depends on air temperature T (K), vapor pressure e (kPa), and atmospheric pressure, p (kPa), as shown in [Equation 1](#).

$$c = 20.067 \sqrt{T \left(1 + \frac{0.32e}{p} \right)}$$
Equation 1

For a given sound path length, d (m), the number of wavelengths, n , in still air is determined with [Equation 2](#).

$$n = \frac{vd}{c}$$
Equation 2

Here v is the frequency of the sound (Hz). When the air is moving, the speed of sound is the sum of the wind speed and the speed of sound in still air. The anemometer transmits a sound pulse in a forward direction, then a similar pulse in the reverse direction. The difference in n between the two points is computed. If the vector magnitude of the wind in the direction of the sound is u (m/s), then

SYSTEM

$$n - \Delta n_+ = \frac{vd}{c + u} \quad \text{Equation 3}$$

$$n + \Delta n_- = \frac{vd}{c - u} \quad \text{Equation 4}$$

for sound traveling with and against the wind. Subtracting the result of [Equation 3](#) from the result of [Equation 4](#) creates [Equation 5](#).

$$\Delta n = \Delta n_- + \Delta n_+ = \frac{2vd u}{c^2 - u^2} \quad \text{Equation 5}$$

Even at the maximum wind speeds for the anemometer, u^2 is only about 1% of c^2 , so the equation can be simplified as shown in [Equation 6](#).

$$u \cong \frac{c^2}{2vd} \Delta n \quad \text{Equation 6}$$

This is the basic equation for the anemometer. Delta (Δ) n is proportional to the phase difference between the forward and reverse sound pulses. The sound comes from a 40 kHz ultrasonic transducer in the head of the anemometer. A sound pulse is transmitted diagonally across the anemometer, bouncing off an acoustic plate in the center. The sound pulse is then received by another transducer in the anemometer head that is opposite the first. Once the sound pulse is received, the receiver becomes the transmitter and the process is repeated. Two more sensors, mounted at 90 degrees from the first two, give the other horizontal component of the wind. The sound travels a total distance of about 65 mm from transmitter to receiver, but d in the equations is just the horizontal distance, which is 27 mm.

If u is the magnitude of the wind vector in the east-west direction (east +) and v is the magnitude in the north-south direction (north +), then wind speed is computed with [Equation 7](#).

$$S = \sqrt{\overline{u^2} + \overline{v^2}} \quad \text{Equation 7}$$

Where the overbar indicates an average of the values sampled every 3 s, wind direction is computed with [Equation 8](#).

$$\theta = \tan^{-1}(\overline{v}/\overline{u}) \quad \text{Equation 8}$$

WARNING: The wind measurement through more frequent SDI-12 commands requires 42 ms to complete. An additional 60 ms are required for the computations to determine phase differences. The anemometer samples every 3 s (or more often if requested through more frequent SDI-12 commands). The gust speed reported is the highest instantaneous wind speed measured during the selected averaging interval (must be >6 s or gusts will equal speed). Wind speeds above 60 m/s are not measured reliably with the phase shift method, so wind speeds measured above 60 m/s will be reported as 60 m/s. Cup anemometers average over a much longer interval than 42 ms, so the gusts measured with a sonic anemometer will have a larger peak-to-mean ratio than a cup anemometer.

3.6 LIMITATIONS

The ATMOS 22 GEN 2 is engineered to be a robust device with minimal downtime. However, it does have limitations that will affect its measurements under some conditions.

3.6.1 SNOW AND ICE ACCUMULATION

Accumulation of snow, ice, or frost can compromise the wind measurements if accumulation occurs in the anemometer acoustic pathway or on the acoustic plate ([Section 4.2](#)).

3.6.2 HEAVY RAIN AND STRONG WIND

During strong storm events, water can splash off of the convex base plate of the anemometer envelope and interrupt the signal passing between the sonic transducers. The smooth, convex base plate helps dissipate the energy of rainwater to minimize splashing and reduce the likelihood that the wind measurements are interrupted. Additionally, specially treated hydrophobic porous polyethylene membranes protect the ultrasonic transducers from direct splashing. Despite these features, heavy rain and strong wind can still cause water to reach the membranes and also cause temporary water buildup on the acoustic plate. The hydrophobic nature of the transducer protective membranes and the quick-draining ability of the acoustic plate should limit wind measurement interruptions to heavy rain events and should bring wind measurement back online soon after extreme conditions abate.

3.7 MEASUREMENTS WITH METER DATA LOGGERS

METER EM60 series and ZENTRA series data loggers query the ATMOS 22 GEN 2 once every minute and record the appropriate averages and maximums from the ATMOS 22 GEN 2 in memory. When the measurement interval is reached, the 1-min measurements are processed into the appropriate averages and maximums and output to final storage (see the [METER logger manual](#) for more information). [Table 2](#) describes the quantities output from the ATMOS 22 GEN 2 and how they are processed in the logger for each ATMOS 22 GEN 2 measurement.

Table 2 ATMOS 22 GEN 2 output quantities processed in METER data logger

Measurement	Data Measurement Frequency	Data Saved by Logger Each Measurement Interval (m = number of minutes)
Wind speed	3 s	Wind run is calculated from average of $20m$ saved values of both horizontal wind vectors
Wind direction	3 s	Weighted direction calculated from average of $20m$ saved values of horizontal wind vectors
Wind gust	3 s	Maximum wind gust recorded over $20m$ measurements during measurement interval
Anemometer temperature	3 s	Average of $20m$ instantaneous temperature measurements
Tilt	60 s	Average of m instantaneous tilt measurements

4. SERVICE

This section contains calibration frequencies, cleaning and maintenance, troubleshooting guidelines, and contact information.

4.1 CALIBRATION

The relationship between wind speed and phase is determined by geometry and the laws of physics. Since the geometry is tightly controlled in manufacturing, no individual anemometer calibration is needed. The phase of each ATMOS 22 GEN 2 anemometer is initially set to zero in a zero wind-speed condition. Extensive wind-tunnel and field testing has shown this to result in accurate wind-speed measurements. A subsample of anemometers is checked monthly for accuracy as part of routine quality assurance (QA) procedures. Routine recalibration of the ATMOS 22 GEN 2 is not necessary.

4.2 CLEANING AND MAINTENANCE

Below are instructions to clean and maintain the ATMOS 22 GEN 2. Cleaning and maintenance should be performed as needed.

1. Make sure nothing is obscuring the temperature sensor or the sonic transducers shown in [Figure 6](#) (cobwebs, leaves, wasp nests, etc.).
2. Check the following areas to make sure they are clear of miscellaneous environmental, animal (specifically bird droppings) and insect debris, or spider webs:
 - a. Anemometer opening
 - b. Acoustic plate
3. Clean the ATMOS 22 GEN 2
 - a. Scrub with light to medium pressure using a warm, damp cloth.
 - b. Completely dry the instrument by removing excess water using a dry cloth.
 - c. Clean around posts and between crevices using a dry brush.
 - d. Be sure the sensor is level after cleaning.

CAUTION

DO NOT immerse the sensor in water.

DO NOT touch the temperature sensor needle ([Figure 6](#)). The wire leads for the temperature sensor needle are very delicate and can be easily damaged.

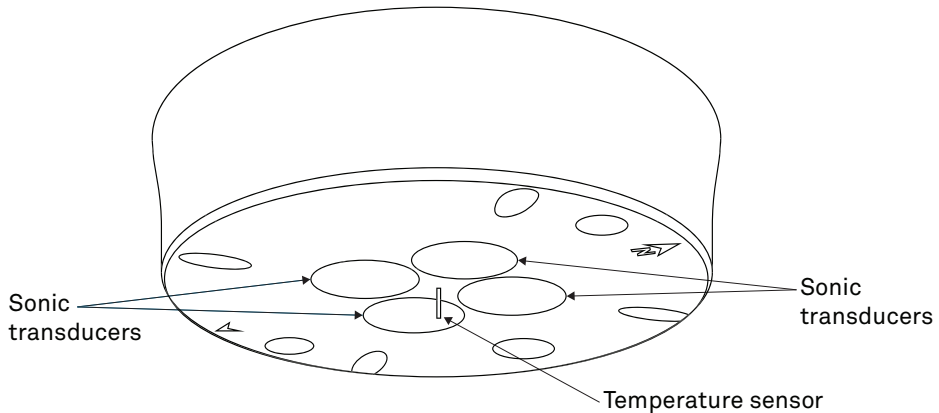

Figure 6 Temperature needle and sonic transducers

4.3 TROUBLESHOOTING

Table 3 Troubleshooting the ATMOS 22 GEN 2

Problem	Possible Solutions
ATMOS 22 GEN 2 not responding	Check power to the sensor. Check sensor cable and 3.5-mm plug integrity. Check data logger wiring to ensure the following connections: <ul style="list-style-type: none"> • Brown—3.6 VDC to 15.0 VDC continuous power supply • Orange—digital data output • Bare—ground Check SDI-12 address. It should be zero for METER data loggers.
No wind speed	Check anemometer pathway to make sure there is no debris blocking the path of the sonic transducer measurement (between transducers and acoustic plate). Check the sonic transducers to make sure that there is no water buildup; if there is moisture, take a dry cloth and dab it away. Check to see if the acoustic plate (Figure 4) is dirty, and clean by flushing with water and dry with a dry cloth (Section 4.2). Be sure the ATMOS 22 GEN 2 is level.

4.4 CUSTOMER SUPPORT

NORTH AMERICA

Customer service representatives are available for questions, problems, or feedback Monday through Friday, 7:00 am to 5:00 pm Pacific time.

Email: support.environment@metergroup.com
sales.environment@metergroup.com

Phone: +1.509.332.5600

Fax: +1.509.332.5158

Website: metergroup.com

EUROPE

Customer service representatives are available for questions, problems, or feedback Monday through Friday, 8:00 to 17:00 Central European time.

Email: support.europe@metergroup.com
sales.europe@metergroup.com

Phone: +49 89 12 66 52 0

Fax: +49 89 12 66 52 20

Website: metergroup.com

If contacting METER by email, please include the following information:

Name	Email address
Address	Instrument serial number
Phone	Description of the problem

NOTE: For products purchased through a distributor, please contact the distributor directly for assistance.

4.5 TERMS AND CONDITIONS

By using METER instruments and documentation, you agree to abide by the METER Group Inc., Terms and Conditions. Please refer to metergroup.com/terms-conditions for details.

REFERENCE

Campbell, Gaylon S. and Michael H. Unsworth. 1979. An Inexpensive Sonic Anemometer for Eddy Correlation. *Journal of Applied Meteorology*. 18 (8):1072–1077.

INDEX

- A**
 - anemometer 11–12
 - applications 1
- C**
 - calibration 17
 - cleaning 17–19
 - communication 7, 8
 - components 14
 - connecting 4–7
- D**
 - data acquisition system 8
 - See also* connecting
- E**
 - email address 19
- F**
 - fax number 19
- I**
 - installation 2–4
- L**
 - limitations 15
- M**
 - maintenance 17–19
 - measurements
 - air temperature 12
 - tilt 8, 13
 - wind direction 8, 11
 - wind gust 8, 11
 - wind speed 8, 11
- P**
 - phone number 19
- S**
 - sensors
 - anemometer 11
 - temperature 12
 - tilt 13
 - specifications
 - cable length 9
 - communication 8
 - compliance 11
 - data logger compatibility 8
 - dimensions 9
 - electrical 9–10
 - measurement 8
 - physical 9
- T**
 - temperature sensor 12–13
 - terms and conditions 19
 - theory
 - air temperature 12–13
 - wind speed and direction 13–15
 - tilt sensor 13
 - troubleshooting 18
- Z**
 - ZENTRA
 - logger 4, 8
 - ZENTRA Cloud 5
 - ZENTRA Utility 5

METER Group Inc.

2365 NE Hopkins Court Pullman, WA 99163
T: +1.509.332.2756 F: +1.509.332.5158
E: info@metergroup.com W: metergroup.com

METER Group GmbH

Mettlacher Straße 8, 81379 München
T: +49 89 1266520 F: +49 89 12665220
E: info.europe@metergroup.com W: metergroup.com

