



METER

TEROS 11/12



TABLE OF CONTENTS

1. Introduction	1
2. Operation	2
2.1 Installation	2
2.2 Connecting	6
2.2.1 Connect to METER Logger	6
2.2.2 Connect to Non-METER Logger	7
2.3 Communication	8
3. System	10
3.1 Specifications	10
3.2 Components	14
3.3 Theory	15
3.3.1 Volumetric Water Content	15
3.3.2 Temperature	15
3.3.3 Electrical Conductivity (TEROS 12 Only)	16
3.3.4 Converting Bulk EC to Pore EC (TEROS 12 Only)	16
3.3.5 Pore Water Versus Saturation Extract EC (TEROS 12 Only)	17
4. Service	19
4.1 Calibrations	19
4.1.1 Mineral Soils	19
4.1.2 Soilless Media	19
4.1.3 Apparent Dielectric Permittivity	20
4.2 Cleaning	20
4.3 Troubleshooting	20

4.4 Customer Support.....	21
4.5 Terms and Conditions	22
References	23
Index	24

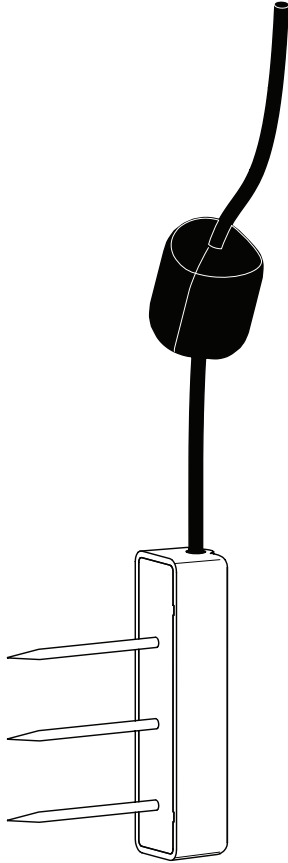

1. INTRODUCTION

Thank you for choosing the TEROS 11 Soil Moisture and Temperature sensor and the TEROS 12 Soil Moisture, Temperature, and Electrical Conductivity (EC) sensor from METER Group.

The TEROS 11/12 sensors are designed to be installed in mineral soils, many types of growing media, and other porous materials. This manual guides the customer through the sensor features and describes how to use the sensor successfully.

TEROS 11/12 sensors are accurate tools for monitoring volumetric water content (VWC), temperature in soil and soilless substrates, and EC (TEROS 12 only). The TEROS 11/12 determines VWC using capacitance/frequency-domain technology. The sensor uses a 70-MHz frequency, which minimizes textural and salinity effects, making the TEROS 11/12 accurate in most mineral soils. The TEROS 11/12 uses a thermistor to measure temperature and EC (TEROS 12 only) using a stainless-steel electrode array.

Prior to use, verify the TEROS 11/12 sensor arrived in good condition. METER recommends testing the sensors with the data logging device and software before going to the field.

2. OPERATION

Please read all instructions before operating the TEROS 11/12 to ensure it performs to its full potential.

⚠ SAFETY PRECAUTIONS

METER sensors are built to the highest standards. Misuse, improper protection, or improper installation may damage the sensor and possibly void the manufacturer's warranty. Before integrating the TEROS 11/12 into a system, follow the recommended installation instructions and have the proper protections in place to safeguard sensors from damage. If installing sensors in a lightning-prone area with a grounded data logger, see the application note [Lightning surge and grounding practices](#).

2.1 INSTALLATION

Follow the steps listed in [Table 1](#) to set up the TEROS 11/12 and start collecting data. For more detailed installation information, consult the [TEROS soil moisture sensor installation best practices](#) video.

Table 1 Installation

<p>Tools Needed</p>	<p>Auger or shovel</p> <p>Secure mounting location for data logger and cable</p> <p>Borehole Installation Tool (optional)</p> 
<p>Preparation</p>	<p>Determine Best Installation Method</p> <p>There are several methods for installing soil moisture sensors. These methods are described in Table 2.</p> <p>Conduct System Check</p> <p>Plug the sensor into the data logger (Section 2.2) to make sure the sensor is functional.</p> <p>Verify all sensors read within expected ranges. The TEROS verification clip gives the best assessment of proper sensor function and accuracy. TEROS 11/12 should read 0.332 (2650 raw) to 0.363 (2730 raw) m^3/m^3 on the verification clip. If a verification clip is not available, test sensor functionality in air and water. The TEROS 11/12 will read $\sim 0.70 \text{ m}^3/\text{m}^3$ in water and a slightly negative value in air.</p>

Table 1 Installation (continued)**Create Hole**

Avoid interfering objects.

- Installations near large metal objects can affect the sensor function and distort readings.
- Large objects like roots or rocks could potentially bend the needles.

Auger or trench a hole to the desired sensor installation depth and direction according to the installation method desired ([Table 2](#)).

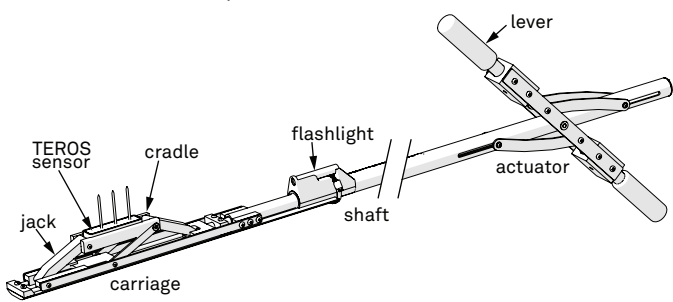
Insert Sensor

Determine sensor orientation. The TEROS 11/12 sensor may be positioned in any direction. However, with the body in a vertical position (as shown below), there is less restriction to water flow. A vertical position will also integrate more soil depth into the soil moisture measurement. Installing the sensor with the body in a horizontal position will provide measurements at a more discreet depth. See [Measurement volume of METER volumetric water content sensors](#) for more information on sensor measurement volume.

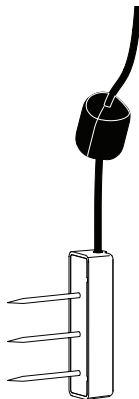
**Sensor body vertical and needles horizontal**

Avoid having any metal located between the sensor and the ferrite core because it can interfere with VWC measurements.

ATTENTION! Minimize air gaps around the sensor. Air gaps around the sensor needles will result in low readings of soil moisture.

1. Load the TEROS 11/12 using the Borehole Installation Tool (BIT).
NOTE: The BIT provides a significant amount of mechanical advantage. See [Table 2](#) for instruction on installing the TEROS 11/12 without the BIT.
2. Lower the tool into the hole or trench with the back of the tool supported by the far wall.
3. Pull the tool lever to activate the jack and insert the sensor into the sidewall

The three tips of the sensor have a tapered shape for easy insertion in almost any kind of soil.

WARNING: When installing sensors in rocky soils, use care to avoid bending sensor needles.

Table 1 Installation (continued)**Secure and Protect Cables**

NOTE: Improperly protected cables can lead to severed cables or disconnected sensors. Cabling issues can be caused by many factors such as rodent damage, driving over sensor cables, tripping over cables, not leaving enough cable slack during installation, or poor sensor wiring connections.

Install cables in conduit or plastic cladding when near the ground to avoid rodent damage.

Gather and secure cables between the TEROS 11/12 and the data logger to the mounting mast in one or more places.

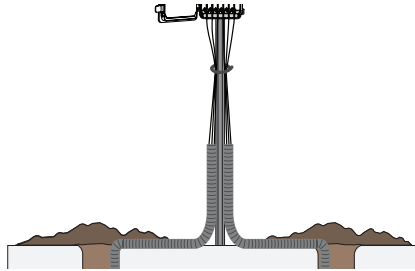

Installation
(continued)

Connect to Data Logger

Plug the sensor into a data logger.

Use the data logger to make sure the sensor is reading properly.

Verify that these readings are within expected ranges.

For more specific instructions on connecting to data loggers, refer to [Section 2.2](#).

Backfill the Hole

Return soil to the hole, packing the soil back to its native bulk density.

Do not hit the ferrite core as this could potentially pull the sensor out of the soil.

[Table 2](#) contains brief descriptions for typical installation methods. Each has its own advantages and disadvantages. For more information about which installation method is best for specific applications, please see the [TEROS soil moisture sensor installation best practices](#) video or contact [Customer Support](#).

Table 2 Installation methods

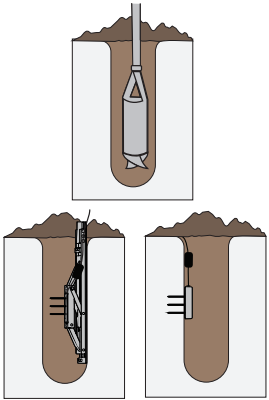
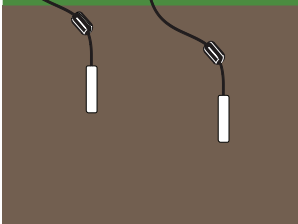
Borehole			
<p>This method uses the Borehole Installation Tool (Table 1) that allows a profile of soil moisture sensors to be installed at different depths within a single augered borehole. A 10-cm (4-in) borehole is augered vertically at the measurement location. The Borehole Installation Tool is then used to install the sensors in the sidewall of the borehole.</p> <p>NOTE: The borehole method requires specialized installation tool available from METER if installing at depths greater than 50 cm.</p>		<p>Advantage</p> <p>Minimizes soil disturbance at measurement site.</p>	<p>Disadvantage</p> <p>Requires a specialized installation tool that can be rented from METER.</p>
Trench			
<p>The trench installation method is best for shallow installations (less than 40 cm). This requires digging a trench with a shovel, excavator, or other tool. The trench needs to be dug to the depth of the deepest installed sensor. For deep installations, this may require a large trench. The sensor is installed carefully by hand into the undisturbed soil of the trench sidewall. The trench is carefully backfilled to preserve the bulk density of the soil and to avoid dislodging the installed sensor by accidentally snagging the ferrite core.</p>		<p>Advantage</p> <p>Does not require specialized equipment.</p>	<p>Disadvantage</p> <p>Large soil disturbance at measurement site.</p> <p>Potentially large excavation effort.</p>

2.2 CONNECTING

The TEROS 11/12 works seamlessly with METER data loggers. The TEROS 11/12 can also be used with other data loggers, such as those from Campbell Scientific, Inc. For extensive directions on how to integrate the sensors into third-party loggers, refer to the [TEROS 11/12 Integrator Guide](#).

TEROS 11/12 sensors require an excitation voltage in the range of 4 to 15 VDC and operate at a 4-VDC level for data communication. TEROS 11/12 can be integrated using DDI serial or SDI-12 protocol. See the [TEROS 11/12 Integrator Guide](#) for details on interfacing with data acquisition systems.

TEROS 11/12 sensors come with a 3.5-mm stereo plug connector ([Figure 1](#)) to facilitate easy connection with METER data loggers. TEROS 11/12 sensors may be ordered with stripped and tinned wires to facilitate connecting to some third-party loggers ([Section 2.2.2](#)).

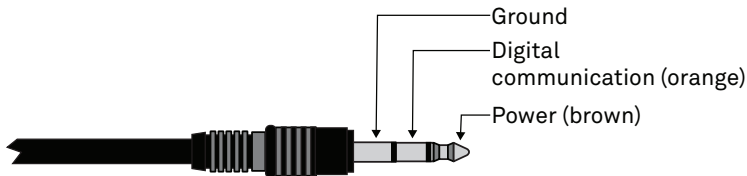

Figure 1 Stereo plug connector

The TEROS 11/12 comes standard with a 5-m cable. It may be purchased with custom cable lengths for an additional fee (on a per-meter basis). In some instances, the cable can be extended beyond 75 m by the user, but this is discouraged for a variety of reasons. Please contact [Customer Support](#) for more details before extending or splicing cables.

2.2.1 CONNECT TO METER LOGGER

The TEROS 11/12 works most efficiently with METER ZENTRA series data loggers. Check the METER [download webpage](#) for the most recent data logger firmware. Logger configuration may be done using either ZENTRA Utility (desktop and mobile application) or ZENTRA Cloud (web-based application for cell-enabled ZENTRA data loggers).

1. Plug the stereo plug connector into one of the sensor ports on the logger.
2. Use the appropriate software application to configure the chosen logger port for the TEROS 11/12.

METER data loggers will automatically recognize TEROS 11/12 sensors.

3. Set the measurement interval.

METER data loggers measure the TEROS 11/12 once every minute and return the average of the 1-min data across the chosen measurement interval.

TEROS 11/12 data can be downloaded from METER data loggers using either ZENTRA Utility or ZENTRA Cloud. Refer to the logger user manual for more information about these programs.

2.2.2 CONNECT TO NON-METER LOGGER

The TEROS 11/12 can be purchased for use with non-METER (third-party) data loggers. Refer to the third-party logger manual for details on logger communications, power, and ground ports. The [TEROS 11/12 Integrator Guide](#) also provides detailed instructions on connecting sensors to non-METER loggers.

TEROS 11/12 sensors can be ordered with stripped and tinned (pigtail) connecting wires for use with screw terminals. Refer to the third-party logger manual for wiring details.

Connect the TEROS 11/12 wires to the data logger illustrated in [Figure 2](#) and [Figure 3](#), with the power supply wire (brown) connected to the excitation, the digital out wire (orange) to a digital input, and the bare ground wire to ground.

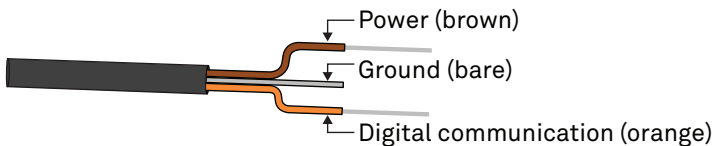

Figure 2 Pigtail wiring

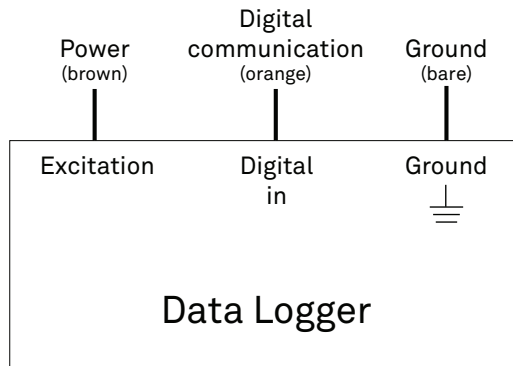

Figure 3 Wiring diagram

NOTE: The acceptable range of excitation voltages is from 4 to 15 VDC. To read TEROS 11/12 sensors with Campbell Scientific, Inc. data loggers, power the sensors from a switched 12-V port or a 12-V port if using a multiplexer.

If the TEROS 11/12 cable has a standard stereo plug connector and needs to be connected to a non-METER data logger, use one of the following two options.

Option 1

1. Clip off the stereo plug connector on the sensor cable.
2. Strip and tin the wires.
3. Wire it directly into the data logger.

This option has the advantage of creating a direct connection and minimizes the chance of the sensor becoming unplugged. However, it then cannot be easily used in the future with a METER readout unit or data logger.

Option 2

Obtain an adapter cable from METER.

The adapter cable has a connector for the stereo plug connector on one end and three wires (or pigtail adapter) for connection to a data logger on the other end. The stripped and tinned adapter cable wires have the same termination as seen in [Figure 3](#); the brown wire is excitation, the orange is output, and the bare wire is ground.

NOTE: Secure the stereo plug connector to the pigtail adapter connections using adhesive-line heat shrink to ensure the sensor does not become disconnected during use.

2.3 COMMUNICATION

The TEROS 11/12 communicates using two different methods:

- DDI serial string
- SDI-12 communication protocol

To obtain detailed instructions, refer the [TEROS 11/12 Integrator Guide](#).

The SDI-12 protocol requires that all sensors have a unique address. TEROS 11/12 sensor factory default is an SDI-12 address of 0. To add more than one SDI-12 sensor to a bus, the sensor address can be changed using a ZSC Bluetooth® sensor interface and the ZENTRA Utility Mobile app as described below:

NOTE: The sensor SDI-12 address must be returned to 0 to work with ZENTRA loggers.

1. Using a mobile device, open the ZENTRA Utility Mobile app.
2. Connect the sensor to the ZSC.
3. Under Sensor Information, select the SDI Address dropdown.
4. Scroll through the options and select the desired SDI-12 address.

NOTE: Address options include 0-9, A-Z, and a-z.

The sensor address can also be changed using the PROCHECK handheld device.

1. Using a PROCHECK connected to the sensor, press the **Menu** button to bring up the **CONFIG** menu.

NOTE: If the PROCHECK does not have this option, please upgrade its firmware to the latest version from the [PROCHECK Sensor Read-Out and Storage System](#) webpage.

2. Scroll down to **SDI-12 Address** and press **Enter**.
3. Press the **UP** or **DOWN** arrows until the desired address is highlighted.

Address options include 0...9, A...Z, and a...z.

4. Press **Enter**.

Detailed information can also be found in the application note [Setting SDI-12 addresses on METER digital sensors using Campbell Scientific data loggers and LoggerNet](#).

When using the sensor as part of an SDI-12 bus, excite the sensors continuously to avoid issues with initial sensor startup interfering with the SDI-12 communications.

3. SYSTEM

This section reviews the components and functionality of the TEROS 11/12 sensor.

3.1 SPECIFICATIONS

MEASUREMENT SPECIFICATIONS

Volumetric Water Content (VWC)

Range

Mineral soil calibration	0.00–0.70 m ³ /m ³
--------------------------	--

Soilless media calibration	0.0–1.0 m ³ /m ³
----------------------------	--

Apparent dielectric permittivity (ϵ_a)	1 (air) to 80 (water)
---	-----------------------

NOTE: The VWC range is dependent on the media the sensor is calibrated to. A custom calibration will accommodate the necessary ranges for most substrates.

Resolution	0.001 m ³ /m ³
------------	--------------------------------------

Accuracy

Generic calibration	±0.03 m ³ /m ³ typical in mineral soils that have solution EC <8 dS/m
---------------------	---

Medium specific calibration	±0.01–0.02 m ³ /m ³ in any porous medium
-----------------------------	--

Apparent dielectric permittivity (ϵ_a)	1–40 (soil range) , ±1 ϵ_a (unitless) 40–80, 15% of measurement
---	---

Dielectric Measurement Frequency

70 MHz

Temperature

TEROS 11

Range	–40 to +60 °C
-------	---------------

Resolution	0.1 °C
------------	--------

Accuracy	±1 °C from –40 to 0 °C ±0.5 °C from 0 to +60 °C
----------	--

NOTE: Temperature measurement, for applicable sensors, may not be accurate if sensor is not fully immersed in the medium of interest, due to longer equilibration time.

TEROS 12	
Range	-40 to +60 °C
Resolution	0.1 °C
Accuracy	±0.5 °C from -40 to 0 °C ±0.3 °C from 0 to +60 °C
Bulk Electrical Conductivity (EC) (TEROS 12 Only)	
Range	0–20 dS/m (bulk)
Resolution	0.001 dS/m
Accuracy	±(5% + 0.01 dS/m) from 0–10 dS/m ±8% from 10–20 dS/m

COMMUNICATION SPECIFICATIONS

Output

DDI serial or SDI-12 communications protocol

Data Logger Compatibility

METER ZL6, EM60, and Em50 data loggers or any data acquisition system capable of 4.0- to 15-VDC power and serial or SDI-12 communication

PHYSICAL SPECIFICATIONS

Dimensions

Length	9.4 cm (3.70 in)
Width	2.4 cm (0.95 in)
Height	7.5 cm (2.95 in)

Needle Length

5.5 cm (2.17 in)

Operating Temperature Range

Minimum	-40 °C
Typical	NA
Maximum	+60 °C

NOTE: Sensors may be used at higher temperatures under certain conditions; contact [Customer Support](#) for assistance.

Cable Length

5 m (standard)
75 m (maximum custom cable length)

NOTE: Contact [Customer Support](#) if a nonstandard cable length is needed.

Cable Diameter

0.165 ± 0.004 in (4.20 ± 0.10 mm) with minimum jacket of 0.030 in (0.76 mm)

Connector Types

Stereo plug connector or stripped and tinned wires

Stereo Plug Connector Diameter

3.5 mm

Conductor Gauge

22-AWG / 24-AWG drain wire

ELECTRICAL AND TIMING CHARACTERISTICS**Supply Voltage (VCC to GND)**

Minimum	4.0 VDC
Typical	NA
Maximum	15.0 VDC

Digital Input Voltage (logic high)

Minimum	2.8 V
Typical	3.6 V
Maximum	3.9 V

Digital Input Voltage (logic low)

Minimum	-0.3 V
Typical	0.0 V
Maximum	0.8 V

Digital Output Voltage (logic high)

Minimum	NA
Typical	3.6 V
Maximum	NA

Power Line Slew Rate

Minimum	1.0 V/ms
Typical	NA
Maximum	NA

Current Drain (during 25-ms measurement)

Minimum	3.0 mA
Typical	3.6 mA
Maximum	16.0 mA

Current Drain (while asleep)

Minimum	NA
Typical	0.03 mA
Maximum	NA

Power-Up Time (DDI serial)

Minimum	80 ms
Typical	NA
Maximum	100 ms

Power-Up Time (SDI-12)

Minimum	NA
Typical	245 ms
Maximum	NA

Power Up Time (SDI-12, DDI disabled)

Minimum	145 ms
Typical	155 ms
Maximum	165 ms

Measurement Duration

Minimum	25 ms
Typical	NA
Maximum	150 ms

COMPLIANCE

Manufactured under ISO 9001:2015

EM ISO/IEC 17050:2010 (CE Mark)

2014/30/EU and 2011/65/EU

EN61326-1:2013 and EN55022/CISPR 22

3.2 COMPONENTS

The TEROS 11/12 sensor measures soil moisture, temperature, and EC (TEROS 12 only) of soil using stainless steel needles (Figure 4).

- TEROS 11/12 sensors measure soil moisture by applying the 70 MHz signal to Needle 1 and using Needle 2 and Needle 3 as the reference for the measurement.
- TEROS 12 sensors measure temperature with an embedded thermistor.
- TEROS 12 sensors measure EC between Needle 2 and Needle 3.

These sensors have a low-power requirement, which makes them ideal for permanent burial in the soil and continuous reading with a data logger or periodic reading with a handheld reader.

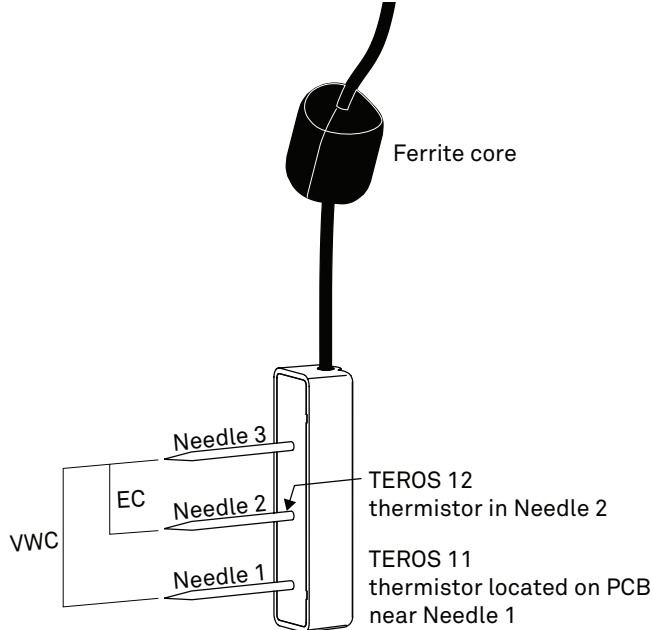

Figure 4 TEROS 11/12 sensor

A ferrite core positioned on the TEROS 11/12 sensor cable 7.6 cm (3 in) away from the sensor head is utilized to isolate the sensor from any interferences in the system. This mitigates any potential noise from the system on the measured sensor data. It is important to not attach anything to the section of cable between the sensor head and the ferrite core as this may influence the measurements.

The TEROS 11/12 VWC measurement sensitivity is contained within a 1,010-mL volume roughly depicted in [Figure 5](#). Please see the application note [Measurement volume of METER volumetric water content sensors](#) for testing protocol and more thorough analysis.

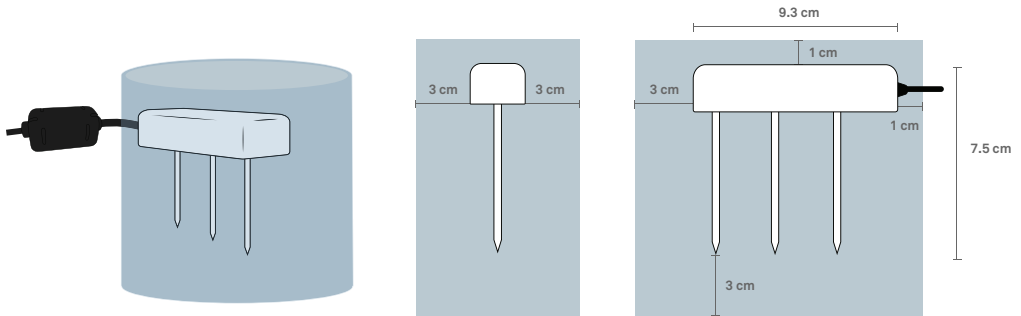

Figure 5 VWC volume of influence

NOTE: The TEROS 11/12 provides instantaneous or near-instantaneous measurements; however, because of the sensitivity of the measurement of the sensor head, the TEROS 11/12 is not well suited for spot measurements of VWC.

3.3 THEORY

The following sections explain the theory of VWC, temperature, and EC (TEROS 12 only) measured by TEROS 11/12.

3.3.1 VOLUMETRIC WATER CONTENT

TEROS 11/12 sensors use an electromagnetic field to measure the dielectric permittivity of the surrounding medium. The sensor supplies a 70-MHz oscillating wave to the sensor needles, which charge according to the dielectric of the material. The charge time is proportional to substrate dielectric and substrate VWC. The TEROS 11/12 microprocessor measures the charge time and outputs a raw value based on the substrate dielectric permittivity. The raw value is then converted to VWC by a calibration equation specific to the substrate ([Section 4.1](#)).

3.3.2 TEMPERATURE

The TEROS 11 uses a small thermistor mounted on the PCB near the lower needle. The TEROS 11 temperature measurement is optimized to be accurate when the TEROS 11 is fully buried in soil or substrate. The TEROS 12 uses a thermistor in the center needle to take temperature readings and responds faster to temperature changes and is better suited for

needle-only insertion into greenhouse and nursery substrates. The TEROS 11/12 sensors output temperature is in degrees Celsius unless otherwise stated in the data logger program, such as in preferences in the ZENTRA software.

NOTE: Even though the sensor head is white, in direct sunlight, the temperature measurement may read high. Use caution when installing the sensor with the sensor head in the sun.

3.3.3 ELECTRICAL CONDUCTIVITY (TEROS 12 ONLY)

EC is the ability of a substance to conduct electricity and can be used to infer the amount of ions that are present in solution. EC is measured by applying an alternating electrical current to two electrodes and measuring the resistance between them. Bulk EC is derived by multiplying the inverse of the resistance (conductance) by the cell constant (the ratio of the distance between the electrodes to their area). TEROS 12 sensor bulk EC measurements are corrected to EC at 25 °C:

$$EC_{25} = \frac{EC_T}{[1 + 0.019(T - 25)]} \quad \text{Equation 1}$$

where EC_{25} is the normalized EC at 25 °C, EC_T is the EC measured by the probe at temperature T , and T is the temperature at the time of measurement. The bulk EC measurement is factory calibrated to be accurate over the range found in the vast majority of soil and growth substrates.

EC measurements above 10 dS/m are sensitive to contamination of the electrodes by skin oils, etc. Follow cleaning instructions in [Section 4.2](#) if measuring the EC of salty soils.

3.3.4 CONVERTING BULK EC TO PORE EC (TEROS 12 ONLY)

For many applications, it is advantageous to know the EC of the solution contained in the soil pores (σ_p), which is a good indicator of the solute concentration in the soil. Traditionally, σ_p is obtained by extracting pore water from the soil and measuring σ_p directly, a time-consuming and labor-intensive process. The TEROS 12 sensor measures the EC of the bulk soil surrounding the sensors (σ_b). A considerable amount of research has been conducted to determine the relationship between σ_b and σ_p . Hilhorst (2000) took advantage of the linear relationship between the soil bulk dielectric permittivity (ϵ_b) and σ_b to accurately convert σ_b to σ_p if the ϵ_b is known. The TEROS 12 sensor measures σ_b and ϵ_b nearly simultaneously in the same soil volume. Therefore, the TEROS 12 is well suited to this method.

The pore water conductivity (σ_p) is determined from [Equation 2](#) (see Hilhorst 2000 for derivation):

$$\sigma_p = \frac{\epsilon_p \sigma_b}{\epsilon_b - \epsilon_{\sigma_b=0}} \quad \text{Equation 2}$$

where

σ_p is the pore water EC (dS/m),

ϵ_p is the real portion of the dielectric permittivity of the soil pore water (unitless),

σ_b is the bulk EC (dS/m) measured directly by the TEROS 11/12,

ε_b is the real portion of the dielectric permittivity of the bulk soil (unitless), and
 $\varepsilon_{ob=0}$ is the real portion of the dielectric permittivity of the soil when bulk EC is 0 (unitless).

Dielectric permittivity of the soil pore water (ε_p) is calculated from soil temperature using [Equation 2](#):

$$\varepsilon_p = 80.3 - 0.37 \times (T_{soil} - 20) \quad \text{Equation 3}$$

where T_{soil} is the soil temperature (in degrees C) measured by the TEROS 12. Use [Equation 8](#) to calculate ε_b from the raw sensor water content.

Finally, $\varepsilon_{ob=0}$ is an offset term loosely representing the dielectric permittivity of the dry soil. Hilhorst (2000) recommended that $\varepsilon_{b=0} = 4.1$ be used as a generic offset. Hilhorst (2000) offers a simple and easy method for determining $\varepsilon_{ob=0}$ for individual soil types, which improves the accuracy of the calculation of ε_p in most cases.

METER testing indicates that the method for calculating σ_p ([Equation 1](#)) results in good accuracy ($\pm 20\%$) in moist soils and other growth media. In dry soils, where VWC is less than $0.10 \text{ m}^3/\text{m}^3$, the denominator of [Equation 1](#) becomes very small, leading to large potential errors. METER recommends that σ_p not be calculated in soils with $\text{VWC} < 0.10 \text{ m}^3/\text{m}^3$ using this method.

3.3.5 PORE WATER VERSUS SATURATION EXTRACT EC (TEROS 12 ONLY)

As noted in [Section 3.3.4](#), pore water EC can be calculated from bulk EC using the sensor-measured dielectric permittivity of the medium. However, pore water EC is not the same as saturation extract EC.

Pore water EC is the EC of the water in the pore space of the soil. This could be measured directly if the soil was squeezed under high pressure to force water out of the soil matrix and that water was collected and tested for EC.

Saturation extract EC is the EC of pore water removed from a saturated paste. Saturation extract EC can be measured directly if distilled water is used to wet the soil until the soil saturates. The soil is then placed on filter paper in a vacuum funnel and suction is applied. An EC measurement on the water extracted from the saturated sample will give the saturation extract EC.

Theoretically, the pore water EC and saturation extract EC are related by the degree of saturation (VWC/total porosity) of the soil.

SYSTEM

An example calculation illustrates this relationship:

Example A soil is at 0.1 m³/m³ VWC, has a pore water EC of 0.7 dS/m, and a dry bulk density of 1.5 Mg/m³.

The total porosity of the soil can be calculated using Equation 4:

$$\begin{aligned}\varphi &= 1 - \frac{\rho_b}{\rho_s} \\ &= 1 - \frac{1.5}{2.65} \\ &= 0.43\end{aligned}\quad \text{Equation 4}$$

The saturation extract EC can be calculated as illustrated in Equation 5:

$$\begin{aligned}\text{Solution EC} &= \frac{\sigma_p \Theta + \sigma_d (\varphi - \Theta)}{\varphi} \\ &= \frac{0.7(0.1) + 0}{0.43} \\ &= 0.162\end{aligned}\quad \text{Equation 5}$$

where

φ is the porosity (unitless),

ρ_b is soil dry bulk density (Mg/m³),

ρ_s is density of the minerals or particle density (assumed to be 2.65 Mg/m³),

σ_p is the pore water EC (dS/m),

σ_d is the EC of distilled water (0 dS/m), and

Θ is VWC (m³/m³).

In practice, solution EC calculated from this method and solution EC taken from a laboratory soil test may not agree well because wetting soil to a saturated paste is very imprecise.

4. SERVICE

This section contains calibration information, calibration frequencies, cleaning guidelines, troubleshooting guidelines, customer support contact information, and terms and conditions.

4.1 CALIBRATIONS

This section includes the mineral soil, soilless media, and dielectric calibrations for TEROs 11/12, where Θ is the VWC (in m^3/m^3), where ε is dielectric, and where RAW is the raw sensor output, when read with a METER or third-party data logger.

The TEROs 11/12 is not sensitive to variation in soil texture and EC because it runs at a high measurement frequency. Therefore, its generic calibration equation should result in reasonable absolute accuracy; $0.03 \text{ m}^3/\text{m}^3$ for most mineral soils up to 8 dS/m saturation extract. Its calibration equations are shown below for mineral soil, soilless growing media (i.e., potting soil, perlite, or peat moss), and dielectric permittivity. However, for added accuracy, customers are encouraged to perform [soil-specific calibrations](#). For more information on how to calibrate sensors or to learn about METER calibration service (calibrations performed for a standard fee), see [soil sensor calibration](#) or contact [Customer Support](#).

4.1.1 MINERAL SOILS

According to METER tests, a single calibration equation will generally suffice for most mineral soil types with ECs from 0 to 8 dS/m saturation extract. VWC (Θ) is given by [Equation 6](#):

$$\Theta(\text{m}^3 / \text{m}^3) = 3.879 \times 10^{-4} \times \text{RAW} - 0.6956 \quad \text{Equation 6}$$

A linear equation is used for the mineral soil calibration because it provides the best predictions of VWC in the range of VWC found in mineral soils, but this equation reaches a maximum at approximately $0.70 \text{ m}^3/\text{m}^3$ in pure water. To display data on a scale from 0 to $1.0 \text{ m}^3/\text{m}^3$, VWC should be modeled with a quadratic equation (which would result in a $1.0 \text{ m}^3/\text{m}^3$ in water). However, METER does not recommend this for mineral soils because it often makes the calibration in the range of VWC found in mineral soil less accurate.

4.1.2 SOILLESS MEDIA

TEROs 11/12 sensors are calibrated in potting soil, perlite, and peat. The goal is to create a generic calibration equation that will work in many nonsoil substrates with an accuracy of better than $0.05 \text{ m}^3/\text{m}^3$. For higher accuracy, performing a media-specific calibration should improve the accuracy to 0.01 to $0.02 \text{ m}^3/\text{m}^3$. The differences between mineral soil and soilless media calibrations are caused by high-air volume in the organic soils that lowers the starting (dry media) dielectric of the sensor.

The calibration for several potting soils, perlite, and peat moss is shown in [Equation 7](#):

$$\Theta(\text{m}^3 / \text{m}^3) = 6.771 \times 10^{-10} \times \text{RAW}^3 - 5.105 \times 10^{-6} \times \text{RAW}^2 + 1.302 \times 10^{-2} \times \text{RAW} - 10.848 \quad \text{Equation 7}$$

4.1.3 APPARENT DIELECTRIC PERMITTIVITY

Apparent dielectric permittivity (ϵ_a) can be used to determine VWC using external published equations such as the Topp equation (Topp et al. 1980). Dielectric permittivity is also used for calculating pore water EC. Dielectric permittivity is given by [Equation 8](#):

$$\epsilon = (2.887 \times 10^{-9} \times \text{RAW}^3 - 2.080 \times 10^{-5} \times \text{RAW}^2 + 5.276 \times 10^{-2} \times \text{RAW} - 43.39)^2 \quad \text{Equation 8}$$

4.2 CLEANING

If the sensor needles become contaminated with oils from contact with skin or another source, it is necessary to clean the needles to ensure accurate EC readings in salty soils with bulk EC greater than 10 dS/m.

1. Clean each needle using a mild detergent such as liquid dish soap and a nonabrasive sponge or cloth.

NOTE: Avoid detergents that contain lotions or moisturizers.

2. Rinse the sensor and needles thoroughly with tap or deionized (DI) water.

NOTE: Do not touch the needles with an ungloved hand or bring them in contact with any source of oil or other nonconducting residue.

4.3 TROUBLESHOOTING

Table 3 Troubleshooting the TEROS 11/12

Problem	Possible Solution
Sensor not responding	Check power to the sensor.
	Check sensor cable and stereo plug connector integrity.
	Check data logger wiring to ensure brown is power supply, orange is digital out, and bare is ground.
Sensor reading too low (or slightly negative)	Check for air gaps around sensor needles. These could be produced below the surface of the substrate when the needle contacts a large piece of material and pushes it out of the way, or if the sensor is not inserted perfectly linearly.
	Ensure the calibration equation being used is appropriate for the media type. There are significant differences between substrate calibrations, so be sure to use the one specific to the substrate.

Table 3 Troubleshooting the TEROS 11/12 (continued)

Problem	Possible Solution
Sensor reading too high	<p>Check to make sure that the media was not packed excessively or insufficiently during sensor installation. Higher density can cause sensor reading to be elevated.</p> <p>Ensure the calibration equation being used is appropriate for the media type. There are significant differences between calibrations, so be sure to use the one most suitable to the substrate, or consider developing a substrate-specific calibration for the particular medium.</p> <p>Some substrates have an inherently high dielectric permittivity (soils of volcanic origin or high titanium, for instance). If the substrate has a dry dielectric permittivity above 6, a custom calibration may need to be performed. Soils with a bulk EC greater than 10 dS/m require substrate specific calibrations (Section 4.1).</p>
Cable or stereo plug connector failure	<p>If a stereo plug connector is damaged or needs to be replaced contact Customer Support for a replacement connector and splice kit.</p> <p>If a cable is damaged follow these guidelines for wire splicing and sealing techniques.</p>

4.4 CUSTOMER SUPPORT

NORTH AMERICA

Customer service representatives are available for questions, problems, or feedback Monday through Friday, 7:00 am to 5:00 pm Pacific time.

Email: support.environment@metergroup.com
sales.environment@metergroup.com

Phone: +1.509.332.5984

Fax: +1.509.332.5158

Website: metergroup.com

EUROPE

Customer service representatives are available for questions, problems, or feedback Monday through Friday, 8:00 to 17:00 Central European time.

Email: support.europe@metergroup.com
sales.europe@metergroup.com

Phone: +49 89 12 66 52 0

Fax: +49 89 12 66 52 20

Website: metergroup.de

SERVICE

If contacting METER by email, please include the following information:

Name	Email address
Address	Instrument serial number
Phone	Description of the problem

NOTE: For products purchased through a distributor, please contact the distributor directly for assistance.

4.5 TERMS AND CONDITIONS

By using METER instruments and documentation, you agree to abide by the METER Group, Inc. USA Terms and Conditions. Please refer to metergroup.com/terms-conditions for details.

REFERENCES

Hilhorst, M. A. 2000. "A Pore Water Conductivity Sensor." *Soil Science Society of America Journal* 64, no. 6:1922–1925.

Topp, G. Clarke, J.L. Davis, and A. Peter Annan. 1980. "Electromagnetic Determination of Soil Water Content: Measurement in Coaxial Transmission Lines." *Water Resources Research* 16, no.3: 574–582.

INDEX

- C**
- calibration **19–20**
 - custom soils calibration **19**
 - mineral soils **19**
 - soilless media **19**
 - cleaning the sensors **16, 20**
 - compliance **14**
 - CE **14**
 - declaration of conformity **14**
 - components **14–15**
 - cable **12**
 - connector types **12**
 - ferrite core **15**
 - needles **11, 14**
 - thermistor **14**
 - configuration
 - See data loggers, connect to METER logger
 - customer support **21**
- D**
- data loggers **6–7, 11**
 - connect to METER logger **6**
 - connect to non-METER logger **7–8**
- E**
- electrical conductivity **16–18**
 - bulk electrical conductivity **16**
 - pore water electrical conductivity **16–17**
 - saturation extract electrical conductivity **17–18**
 - email address **21**
- F**
- fax number **21**
 - ferrite core
 - about **15**
- I**
- installation
 - installation tool **2**
 - methods **5–6**
 - borehole **5**
 - trench **5**
 - preparation **2**
 - tools needed **2**
- M**
- maintenance
 - See cleaning the sensors
- P**
- phone number **21**
- R**
- references **23**
- S**
- safety **2**
 - soil moisture **14**
 - specifications **10–13**
 - data logger compatibility **11**
 - dielectric measurement frequency **10**
 - EC
 - See specifications, electrical conductivity
 - electrical and timing characteristics **11–13**
 - electrical conductivity **10**
 - output **10**
 - physical specifications **11**

temperature **10**
volume of influence **15**
volumetric water content **10**

VWC

See specifications, volumetric water content

T

temperature
theory **15**
terms and conditions **22–23**
theory **15–18**

electrical conductivity **16–18**
See also electrical conductivity

temperature **15**
volumetric water content **15**

VWC

See theory, volumetric water content

troubleshooting **20–21**

V

volumetric water content
specifications **10**
theory **15**

METER Group, Inc.

2365 NE Hopkins Court Pullman, WA 99163
T: +1.509.332.2756 F: +1.509.332.5158
E: info@metergroup.com W: metergroup.com

METER Group AG

Mettlacher Straße 8, 81379 München
T: +49 89 1266520 F: +49 89 12665220
E: info.europe@metergroup.com W: metergroup.de

