



METER

TEROS BIT

BOREHOLE INSTALLATION TOOL



For Intended Use

This product is intended to be used to install environmental sensors underground. The product may only be used according to the instructions as described in this document. METER is not liable for bodily harm or property damage resulting from the use of this product outside of the described function.

© 2023. All rights reserved.

1. INTRODUCTION

Thank you for purchasing the TEROS Borehole Installation Tool (TEROS BIT), designed for use with the TEROS 10, TEROS 11/12, and TEROS 21 soil moisture sensors to make installation easier and minimize soil disturbance. The TEROS BIT can install these sensors to depths between 40 cm to 2 m. Additional extension rods may be purchased separately that can add installation maximum depths of 10 m.

⚠ PRECAUTION

METER instruments are built to the highest standards, but misuse, improper protection, or improper installation may damage the sensor and possibly void the manufacturer's warranty. Before using the TEROS BIT, make sure to follow the recommended installation instructions and have the proper protections in place to safeguard sensors from damage.

Verify contents include all components indicated below:

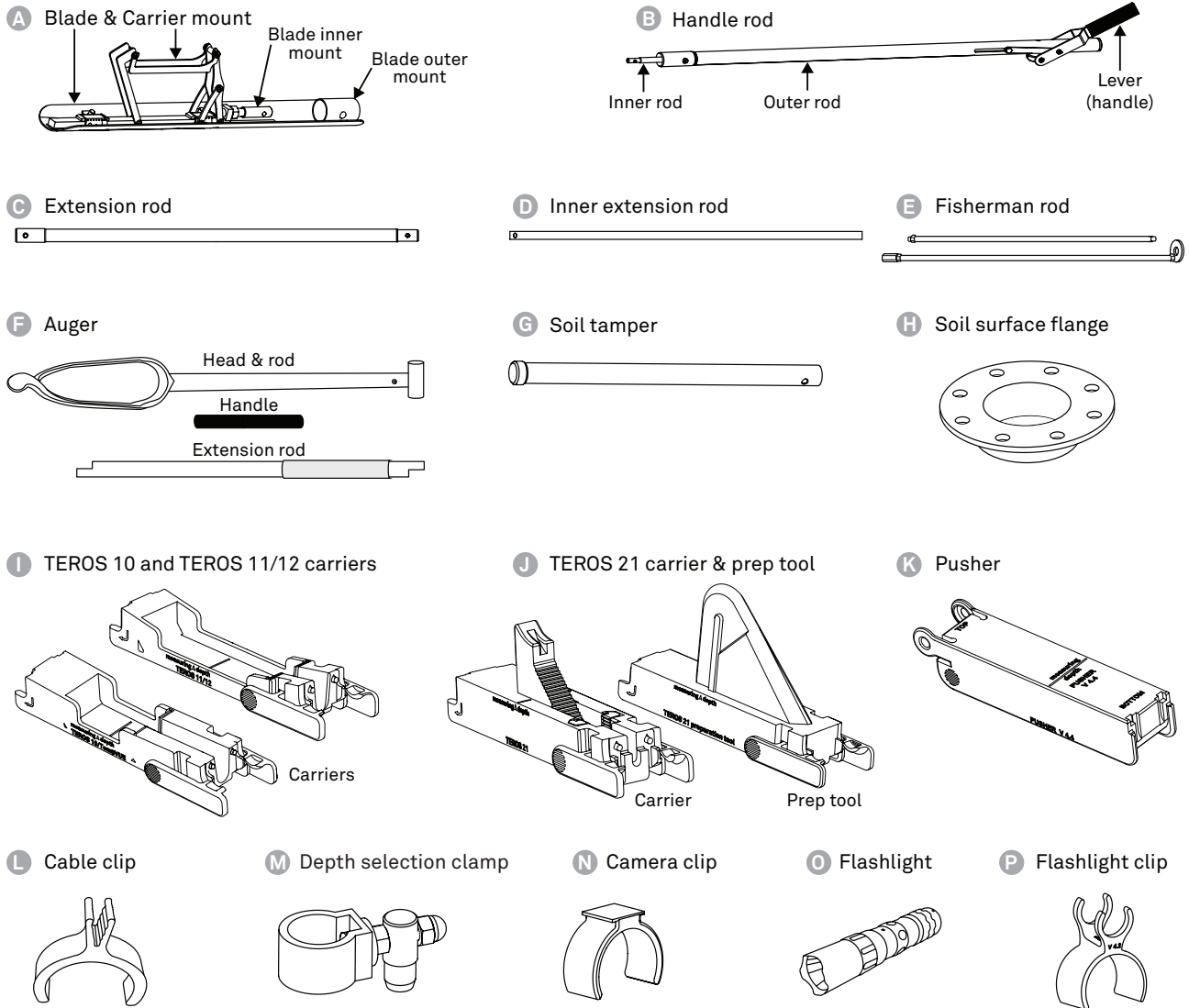

Other items included but not shown here:

- Canvas carrying case
- Plastic tarp

Figure 1 TEROS BIT components

1.1 EXTENSION RODS SOLD SEPARATELY

Additional TEROS BIT extension rods may be ordered from METER for installations down to a 10 m maximum depth.

1.2 OPTIONAL CAMERA

Attaching a camera to the TEROS BIT is optional. METER recommends purchasing an [AOBOCAM Mini Camera, Model Q18](#) ([meter.ly/mini-camera-q18](#)).

1.3 ADDITIONAL RECOMMENDED TOOLS

METER recommends having the following tools available.

- Shovel—approximately 10 cm wide used to backfill the soil in the borehole after installation
- Permanent marker and white tape—used to mark the depth on sensor cables
- Folding ruler—used to mark the depth on the Auger when predrilling the borehole
- Bubble level—used to make sure the Auger is straight when drilling the borehole
- Flashlight—used to verify the installation before removing the TEROS BIT from borehole ([Section 4.2](#))

2. PREPARE THE INSTALLATION SITE

The first step of the installation process is choosing a location that best represents the entire field or catchment (vegetation, microclimate, and soils should represent the entire field/area), assemble the auger ([Section 2.1](#)) and hand drill the borehole to the desired depth ([Section 2.2](#)).

This section describes how to assemble the TEROS BIT and prepare the installation site.

2.1 ASSEMBLE THE AUGER

1. **[OPTIONAL]** Assemble the auger handle and extension rod.

If the extension rod is not needed, go to [step 2](#).

- a. Attach the end of the Auger extension rod (C) to the end of the Auger rod (A). ([Figure 2](#))
- b. Align the connector sleeve slot on the Auger handle rod (B) with the connection buttons.
- c. Slide the connection sleeve on the extension rod down toward the Auger until the connection button is in the sleeve slot.
- d. Rotate the connection sleeve to lock it in place.
- e. Continue on to [step 2](#).

2. **[REQUIRED]** Assemble the Auger handle rod and the Auger rod ([Figure 2](#)).

- a. Attach the end of the Auger handle rod (B) to the end of the Auger rod (A) or the Extension rod (D).

NOTE: If the Auger extension rod (C) is attached to the Auger rod (A), this step will be to connect the end of the Auger extension rod (D) to the end of the Auger handle (B).

- b. Align the connection sleeve slot on the Auger handle rod with the connection button.
- c. Slide the connection sleeve down the handle rod toward the Auger or extension rod until the connection button is in the sleeve slot.
- d. Rotate the connection sleeve to lock it in place.
- e. Insert the handle into the opening at the top of the handle
- f. Screw the handle in place.

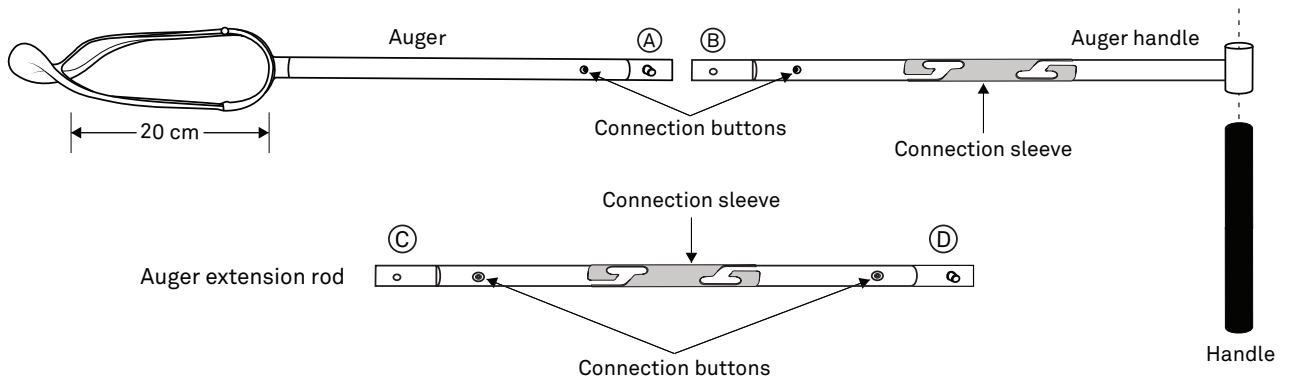

Figure 2 Assemble auger and extension rod

3. **[REQUIRED]** Lay out a large tarp or piece of plastic (included; [Figure 3](#)). Soil removed from the borehole should be placed on the tarp or plastic in separate piles in the order removed.

NOTE: METER recommends labeling the tarp as illustrated below for correct backfilling ([Figure 3](#)).

2.2 HAND DRILL BOREHOLE

NOTE: Dig the borehole an extra 20 cm beyond the required installation depth (equivalent to the blade length).

⚠ CAUTION

Beware of ground cables or pipes when drilling the borehole.

1. Place a level on top of the Auger handle to make sure the borehole goes straight down.
2. Mark the required installation depth on the auger with the folding rule and the marker or white tape.
3. Place the Auger tip on the soil surface and turn, rotating clockwise one-half a turn. This will ensure the soil material sits loose in the Auger head.
4. Remove the soil from the borehole in 5 to 20-cm increments so the soil remains loose in the auger. To empty soil from the auger, rotate the auger so the open face is pointed down and tap the auger on the ground.
5. Place the removed soil on the tarp in the order of soil horizons (i.e., deepest soil removed should be replaced first) for correct backfilling ([Figure 3](#)).
6. Record the corresponding depths on the tarp with the permanent marker next to each pile of removed soil.

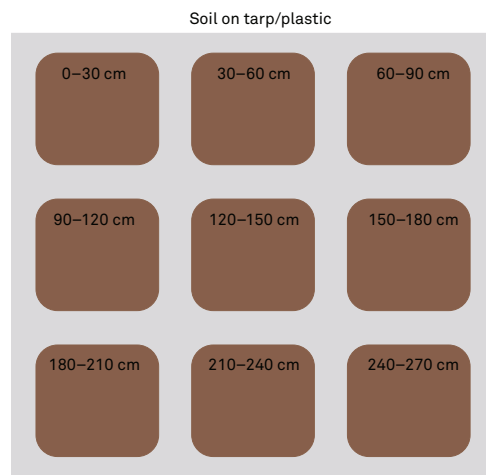

Figure 3 Example of a labeled tarp with piles of soil

7. Repeat [step 4](#) through [step 6](#) until the borehole is 20 cm deeper than the (lowest) installation depth. In soft, loose soils it may be necessary to widen the top of the borehole to make it easier to get the TEROS BIT started without disturbing the mounted sensor.

ASSEMBLE TEROS BIT

8. Make sure that the required drilling depth for installation is reached using the measuring label on the TEROS BIT outer rod.
9. Place the flange (as shown in [Figure 4](#)) on the soil surface over the borehole opening and ensure the bottom of the large ring is flush with the soil surface.

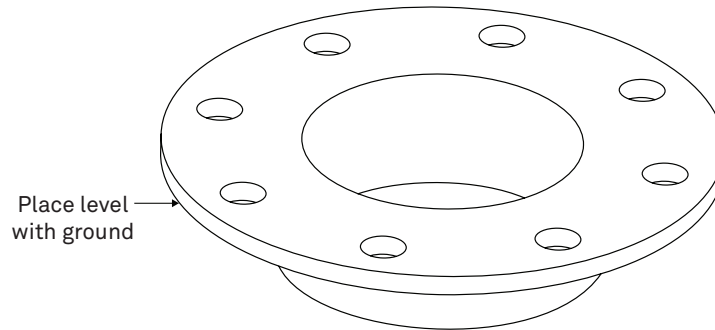

Figure 4 Flange

3. ASSEMBLE TEROS BIT

After the site is prepared, assemble the TEROS BIT and insert the appropriate carrier and sensor into the carrier mount using the following instructions.

For depths greater than 1 m (39.4 in) start with [Section 3.1](#) and add the required number of extension rods, as needed, to reach desired depth. The length of each extension rod is 1 m (39.4 in). The shallowest installation depth is 38 cm.

For depths no deeper than 1 m (39.4 in) start with [Section 3.2](#) because no extension rod will be required.

3.1 [OPTIONAL] CONNECT EXTENSION ROD TO HANDLE

NOTE: This section is only needed for installations deeper than 1 m (39.4 in).

1. Connect the handle inner mount to the inner extension rod ([Figure 5](#)).
Move the handle lever to move the handle inner rod, as necessary.
2. Press the connector buttons and push the rods together until they are properly seated.

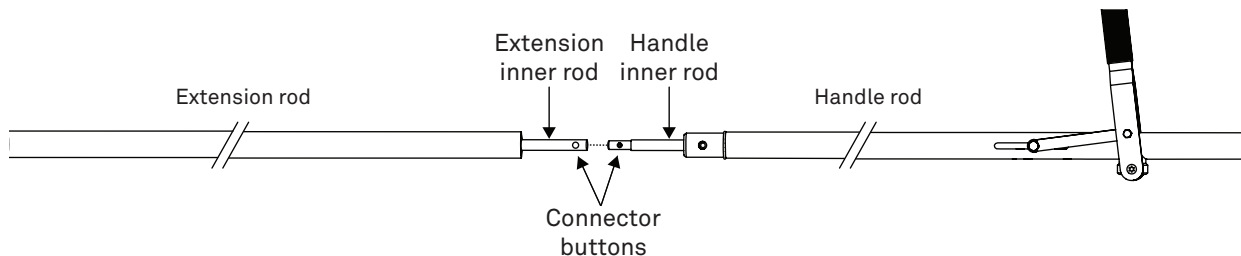

Figure 5 Connect inner extension rod to inner handle rod

3. Slip the outer extension rod over the inner extension rod.
Move the handle lever to move the handle rod and extension rod together, as necessary.
4. Connect the outer extension rod to the handle rod ([Figure 6](#)).

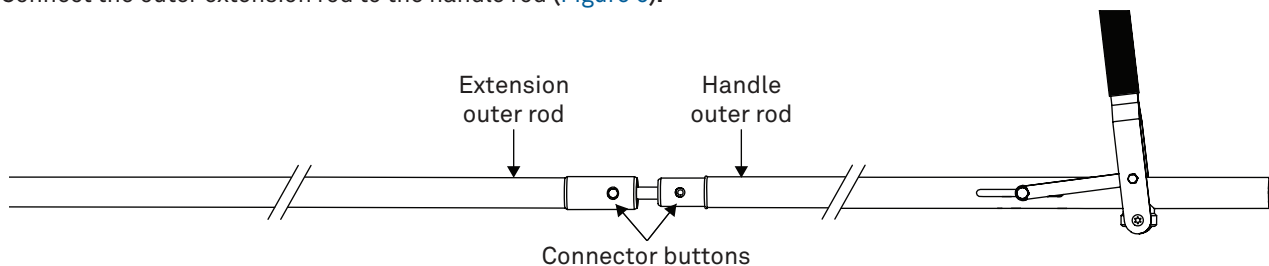

Figure 6 Connect outer extension rod to outer handle rod

3.2 [REQUIRED] CONNECT BLADE TO HANDLE OR EXTENSION ROD

1. Move the handle lever toward the blade to extend the inner rod, as necessary, for easier installation.
2. Press the connector buttons and push the two rods together until the connector button snaps and is properly seated.
3. While moving the handle lever down toward the blade, press the connector buttons on the inner rods.
4. Slightly extend the sensor carrier mount by moving the handle lever to the installed position to make connecting the handle rod and blade easier (Figure 7).
5. Connect the outer handle or extension rod and the blade outer mount.

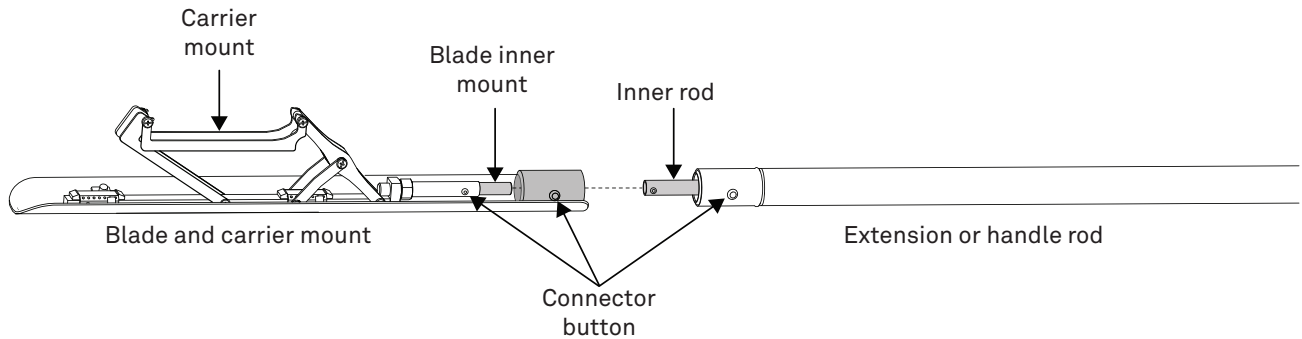

Figure 7 Connecting blade to handle or extension rod

3.3 [OPTIONAL] MOUNT ADDITIONAL TOOL ATTACHMENTS

This section identifies the option tools that can be mounted on the TEROS BIT.

3.3.1 FLASHLIGHT CLIP

1. Mount the flashlight clip on the side of the lower end of the rod (Figure 8).
2. Click the flashlight into the clip.

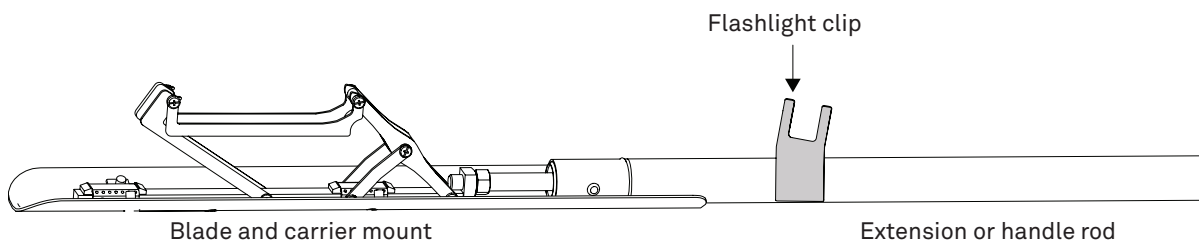

Figure 8 Flashlight clip mounted

3.3.2 CAMERA CLIP

NOTE: METER does not provide a camera. However, METER recommends the following camera: AOBOCAM Mini camera, Modell n° Q18 (Section 1.2).

1. Mount the camera clip on the lower end of the rod right above the blade (Figure 9). Mounting the camera to the side will allow the user to be able to see the sensor insertion.
2. Click the camera onto the clip.

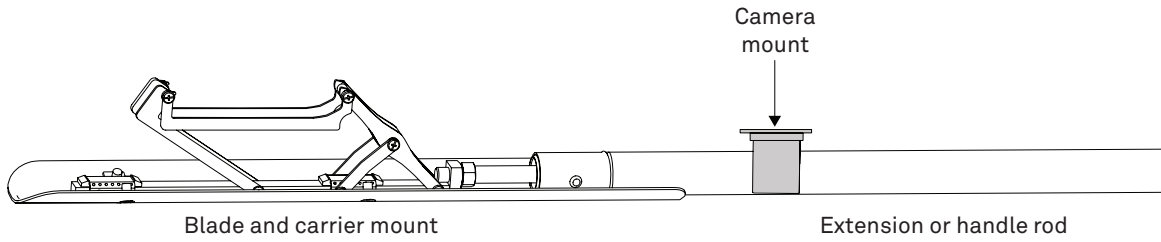

Figure 9 Mounted camera clip

4. INSTALL SENSORS

This section describes how to install the TEROS 10, 11, or 12 sensors. Refer to [Section 4.2](#) for TEROS 21 sensor installation instructions.

4.1 TEROS 10-11-12 INSTALLATION

Always install the deepest sensor first. The preparation tool, sensor carrier and sensor should only be inserted while the carrier mount is extended as shown in [Figure 12](#). [Figure 10](#) shows the three different handle lever positions referenced in the following instructions.

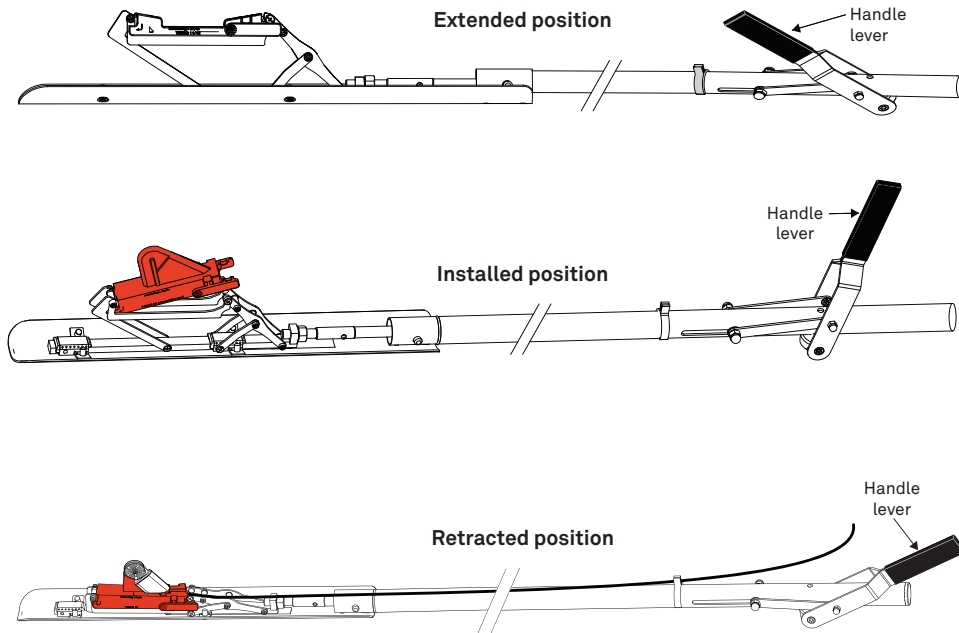

Figure 10 Handle lever positions

4.1.1 [REQUIRED] MOUNT SENSOR CARRIER

⚠ CAUTION

Only move the carrier mount using the handle lever to avoid injuries.

1. Select the appropriate carrier that corresponds to the sensor to be installed ([Figure 11](#)).

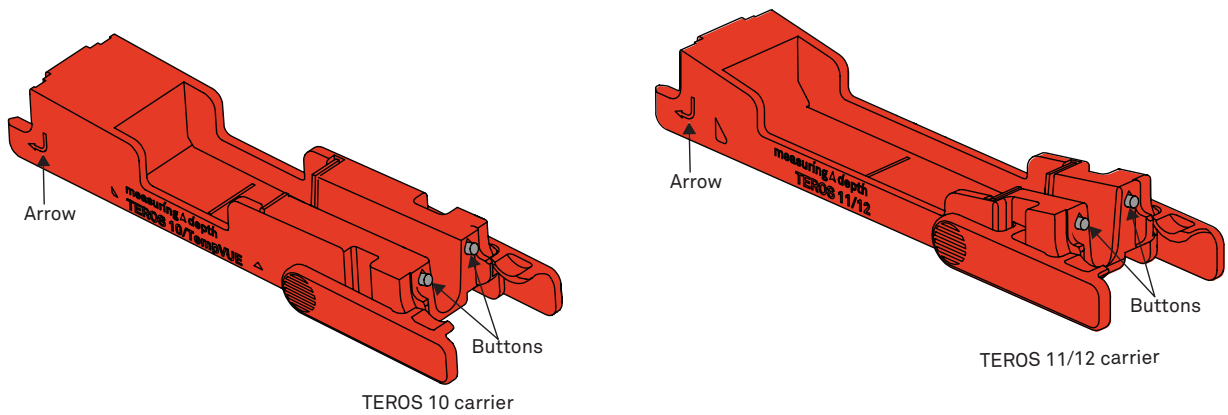

Figure 11 TEROS 10 and 11/12 sensor carriers

2. Find the **Arrow** at one end of the sensor carrier (Figure 11).
3. Slide the carrier end that the **Arrow** points to into the carrier mount (Figure 12).
4. Press down on the top of the carrier to seat it securely into the carrier mount.
If the carrier does not snap down into the carrier mount, spread the release tabs on each side and move the carrier down into the carrier mount.

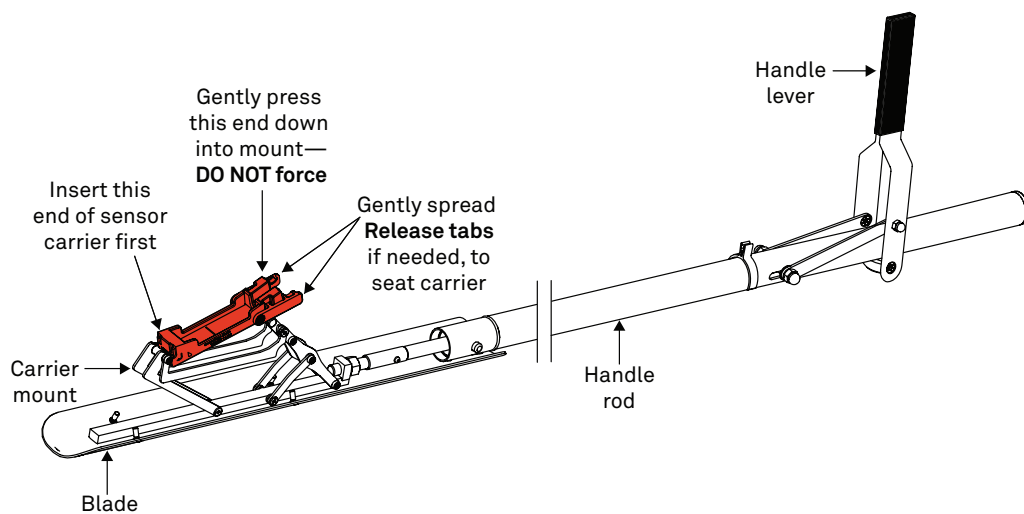

Figure 12 Insert sensor carrier

4.1.2 [REQUIRED] INSERT SENSOR INTO SENSOR CARRIER

NOTE: To be able to recall the installation depth of the respective sensor, write down the intended installation depth onto a piece of white tape attached at the end of the cable.

1. Position the sensor into the corresponding carrier (Figure 13 shows the TEROS 12 inserted into the carrier).

⚠ CAUTION

Be extremely careful when handling the sensors with needles. The sensor needles are very sharp.

NOTE: The sensors can only be inserted while the carrier mount is extended position as shown in Figure 13. When the handle lever is moved into the retracted position, the two buttons on the front of the sensor carrier extend (Figure 11) to hold the sensor in place.

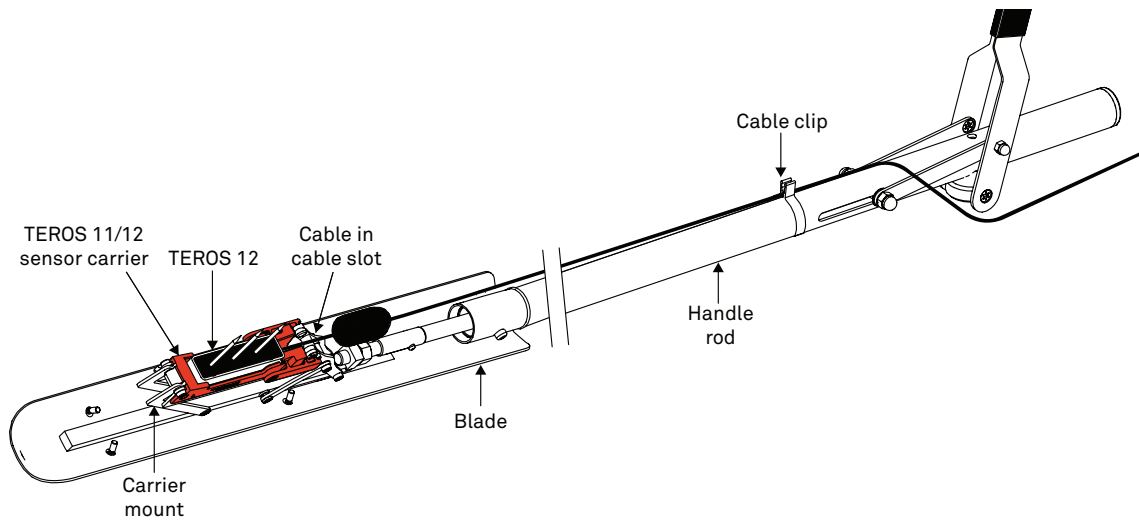

Figure 13 TEROS 12 sensor inserted in sensor carrier with mount extended

2. Press lightly against the sensor to make sure it is seated well in the carrier.
3. Press the sensor cable into the carrier cable slot (Figure 13).
4. Press the sensor cable into the cable clip attached to the handle rod below the lever (Figure 14).

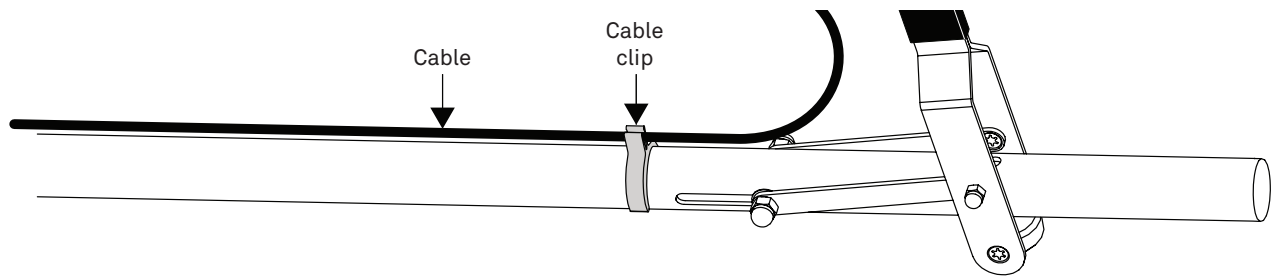

Figure 14 Cable clip on handle

5. Move the handle lever to the vertical position. This retracts the carrier mount to secure the sensor in preparation to insert the TEROS BIT into the borehole.

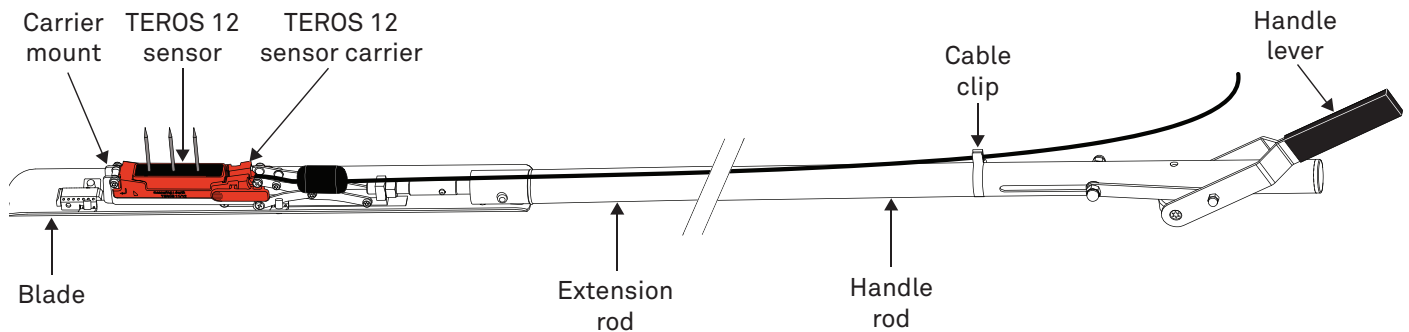

Figure 15 Handle lever in vertical position to retract carrier mount

4.1.3 [REQUIRED] INSERT THE TEROS BIT INTO BOREHOLE

1. Attach the depth selection clamp at the desired depth marked on the handle or extension rod (Figure 16).
2. Set the depth selection clamp to the desired depth marked on the handle or extension rod.

NOTE: The lower edge of the depth selection clamp gets adjusted to the intended installation depth marked on the rod.

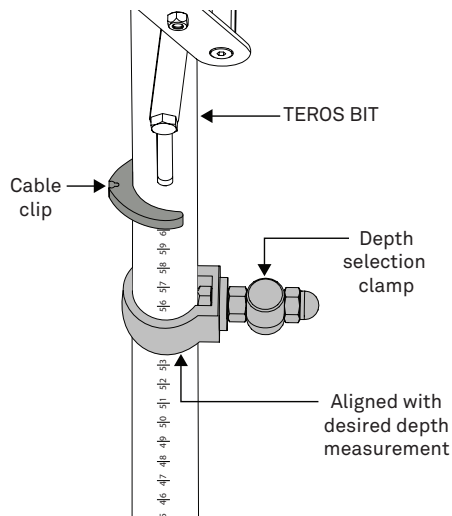

Figure 16 Depth selection clamp

3. Mark the flange hole to be used (Figure 17).

4. Insert the TEROS BIT into the borehole.

NOTE: When installing sensors at multiple depths install the deepest sensor first and use alternating flange holes in order to prevent cable damage.

5. Place the depth selection clamp into the marked flange hole.

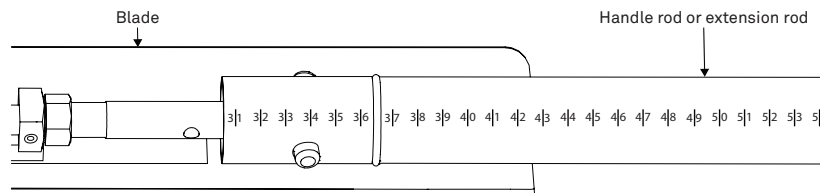
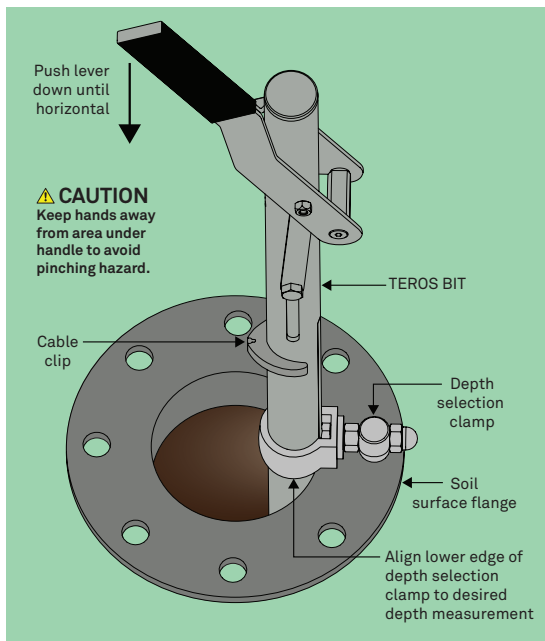

Figure 17 Insert TEROS BIT into borehole

6. Drive the sensor into the borehole sidewall at the desired depth by firmly and slowly pushing the handle lever down until it is in the horizontal position.

This fully extends the carrier mount 10 cm away from the blade so the sensor needles go into the borehole wall.

NOTE: If installation is in loose soil (sand or gravel), the edges of the the borehole opening may collapse, making the opening diameter larger.

CAUTION

To prevent sensor damage, stop installation immediately if resistance is encountered. If the handle lever cannot be easily pressed down into a horizontal position, consider selecting another location in the borehole to avoid damage to the sensor and TEROS BIT.

Keep hands clear of the area below the handle lever to avoid potential pinching hazard.

7. Once the sensor is installed in the borehole sidewall, firmly and slowly move the handle lever up to the retracted position to move the sensor mount away from the sensor.

8. Make sure the sensor remains in the borehole sidewall before removing the TEROS BIT from the borehole by using a flashlight or the optional mounted flashlight.
9. Pull the TEROS BIT out of the borehole.
If installing sensors in loose soils, it may be necessary to stand on or somehow secure the flange to keep it from moving as the TEROS BIT is removed.

⚠ CAUTION

Be aware of the sensor cable position while removing the TEROS BIT to prevent removing the sensor accidentally

10. After all sensors are installed, refer to [Section 5](#) for instruction on how to backfill the soil that was removed from the borehole in [Section 2.2](#).

4.1.4 [OPTIONAL] USE SENSOR PUSHER

To ensure the sensor is firmly seated into the borehole sidewall, use the pusher carrier with the TEROS BIT to push the sensor in further.

⚠ CAUTION

Do not use sensor pusher for the TEROS 21 as it can cause damage to the sensor.

1. To release the sensor carrier, push the handle lever to the extended position.
2. Remove the sensor carrier from the carrier mount by pressing the release tabs and lifting the carrier out of the mount.
3. With the carrier mount still in the extended position, slide the pusher carrier end that the **Arrow** points to into the carrier mount.
4. Press down on the top of the pusher to seat it securely into the carrier mount.
5. Move the carrier mount into the retracted position
6. Lower the TEROS BIT into the borehole.
7. Place the depth selection clamp into the same marked flange hole used to insert the sensor.
8. Move the carrier mount firmly and slowly to the extended position to move the pusher carrier against the sensor.
This pushes the sensor further into the borehole wall.
9. Move the handle lever firmly and slowly to the retracted position.
10. Pull the TEROS BIT out of the borehole.
If installing sensors in loose soils, it may be necessary to stand on or somehow secure the flange to keep it from moving as the TEROS BIT is removed.

⚠ CAUTION

Be aware of the sensor cable position while removing the TEROS BIT to prevent removing the sensor accidentally

12. After the deepest sensor is installed, follow [Section 4.1.1](#) through [Section 4.1.4](#) to install additional sensors at various depths using different flange hole positions.
13. After all sensors are installed, refer to [Section 5](#) for instruction on how to backfill the soil that was removed from the borehole in [Section 2.2](#).

4.2 TEROS 21 SENSOR INSTALLATION

This section describes how to install the TEROS 21 sensor. Refer to [Section 4.1](#) for installation instructions for the TEROS 10, 11, or 12.

4.2.1 [REQUIRED] CREATE TEROS 21 PILOT HOLE

Always install the deepest sensor first. The preparation tool, sensor carrier and sensor should only be inserted while the carrier mount is extended (handle lever in a horizontal position) as shown in [Figure 19](#) and [Figure 23](#).

⚠ CAUTION

Only move the carrier mount using the handle lever to avoid injuries.

NOTE: To be able to recall the installation depth of the respective sensor, write down the intended installation depth onto a piece of white tape attached at the end of the cable.

1. Select the preparation tool ([Figure 18](#)).

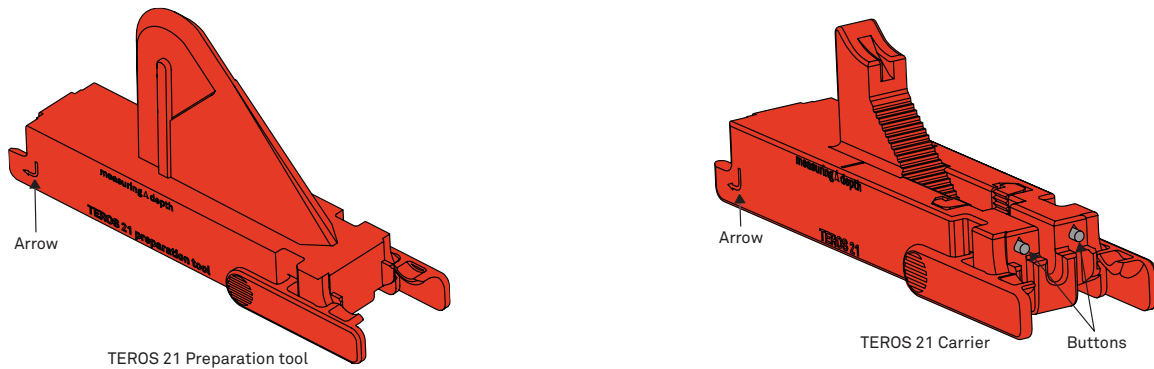

Figure 18 TEROS 21 preparation tool and sensor carrier

2. Find the **Arrow** at one end of the preparation tool (Figure 18).
3. Slide the tool end that the **Arrow** points to into the carrier mount (Figure 19).
4. Press down on the top of the tool to seat it securely into the carrier mount.
If the tool does not snap down into the carrier mount, spread the release tabs on each side and move the tool down into the carrier mount.

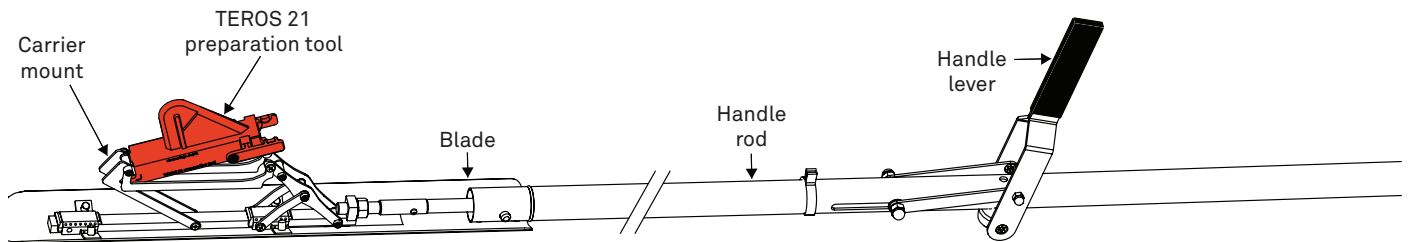

Figure 19 Mount preparation tool

5. Set the depth selection clamp to the desired depth marked on the handle or extension rod.
NOTE: The lower edge of the depth selection clamp gets adjusted to the intended installation depth.
6. Mount the depth selection clamp on the handle or extension rod if it is not already attached. (Figure 20).
7. Move the depth selection clamp to the desired depth mark on the rod (Figure 20).
NOTE: The lower edge of the depth selection clamp gets adjusted to the intended installation depth.

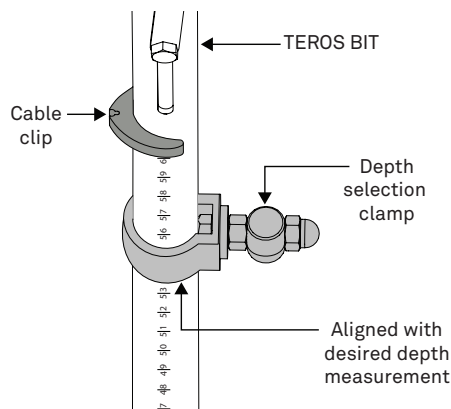

Figure 20 Depth selection clamp

8. Mark the flange hole to be used with a permanent marker or white tape.
9. Insert the TEROS BIT into the borehole.
NOTE: When installing multiple sensors at various depths install the deepest sensor first and use alternating flange holes in order to prevent cable damage.
10. Place the depth selection clamp into the marked flange hole (Figure 20).

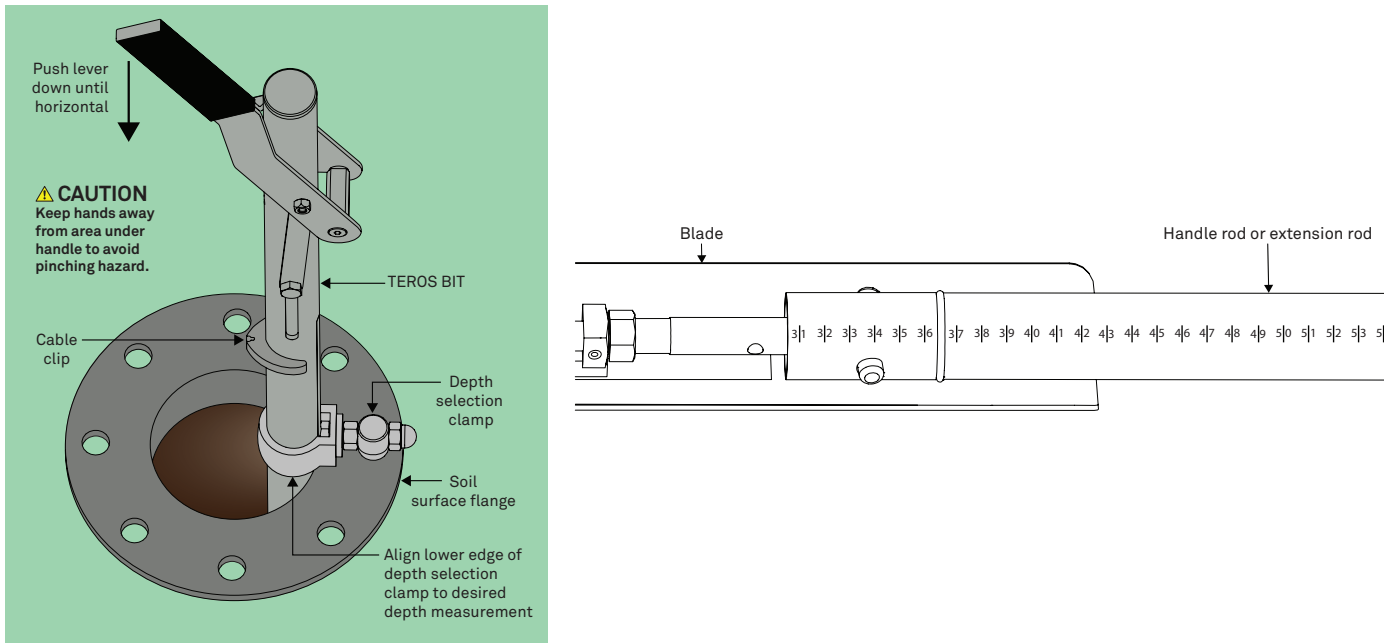

Figure 21 Insert TEROS BIT into borehole

11. Firmly and slowly push the handle lever up into the extended position to drive the preparation tool into the borehole sidewall at the desired depth.

This fully extends the carrier mount 10 cm away from the blade so the preparation tool goes into the borehole wall to make a pilot hole for the TEROS 21.

NOTE: If installation is in loose soil (sand or gravel), the edges of the the borehole opening may collapse, making the opening diameter larger.

CAUTION

To prevent sensor damage, stop preparation tool installation immediately if resistance is encountered. If the handle lever cannot be easily pressed down, consider selecting another location in the borehole to avoid damage to the preparation tool and TEROS BIT.

Keep hands clear of the area below the handle lever to avoid potential pinching hazard.

4.2.2 [REQUIRED] REMOVE THE PREPARATION TOOL

1. Firmly and slowly move the handle lever up into the retracted position.
2. Make sure the preparation tool is completely removed from the borehole wall before removing the TEROS BIT from the borehole using a flashlight or the optional mounted flashlight.
3. Carefully remove the TEROS BIT from the borehole.
If installing sensors in loose soils, it may be necessary to stand on or somehow secure the flange to keep it from moving as the TEROS BIT is removed.
4. Remove the preparation tool from the carrier mount by pressing the release tabs on both sides of the tool and lifting the tool out of the carrier mount.

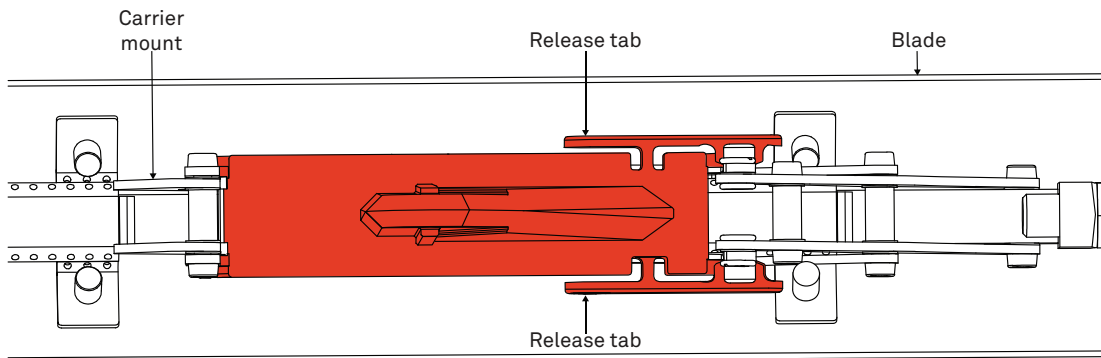

Figure 22 Remove preparation tool

4.2.3 [REQUIRED] MOUNT SENSOR CARRIER

NOTE: To be able to recall the installation depth of the respective sensor, write down the intended installation depth onto a piece of white tape attached at the end of the cable.

1. Make sure the carrier mount is in the extended position.
2. Find the **Arrow** at one end of the TEROS 21 sensor carrier (Figure 18).
3. Slide the carrier end that the **Arrow** points to into the carrier mount (Figure 23).
4. Press down on the top of the carrier to seat it securely into the carrier mount.

If the carrier does not snap down into the carrier mount, spread the release tabs on each side and move the carrier down into the carrier mount.

NOTE: The sensor should only be inserted while the carrier mount is extended (handle lever in a horizontal position).

CAUTION

Only move the carrier mount using the handle lever to avoid injuries.

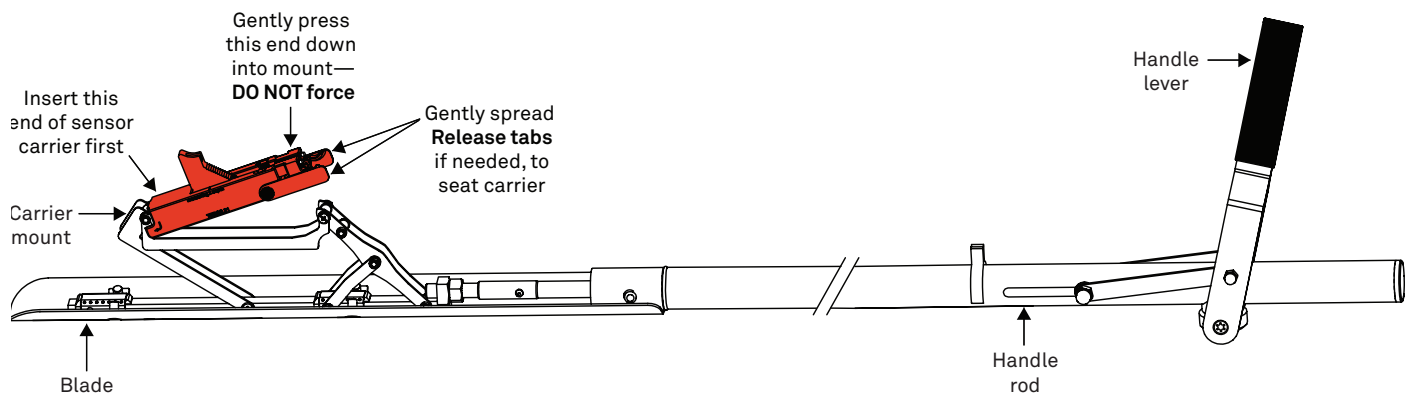

Figure 23 Mount the TEROS 21 sensor carrier

When the handle lever is raised to the vertical position, the carrier mount retracts and the two buttons (Figure 18) on the sensor carrier extend, holding the sensor in place. The carrier mount is in the retracted position.

4.2.4 [REQUIRED] PREPARE A SLURRY OF NATIVE SOIL.

Pack the slurry of native soil onto the TEROS 21 discs until all ceramic is covered (Figure 24).

To ensure hydraulic contact all ceramic must be covered with soil.



Figure 24 Pack native soil slurry on TEROS 21 sensor

4.2.5 [REQUIRED] INSERT SENSOR INTO SENSOR CARRIER

1. Position the sensor into the carrier (Figure 25 shows the TEROS 21 inserted into the carrier).
2. Press lightly against the sensor to make sure it is seated well in the carrier.

3. Press the sensor cable into the cable slot on the sensor carrier (Figure 20).

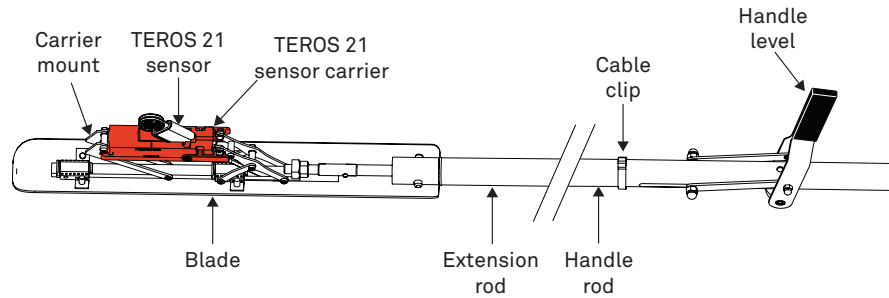

Figure 25 TEROS 21 sensor inserted in sensor carrier

4. Press the sensor cable into the cable clip mounted on the handle rod right below the handle lever (Figure 26).

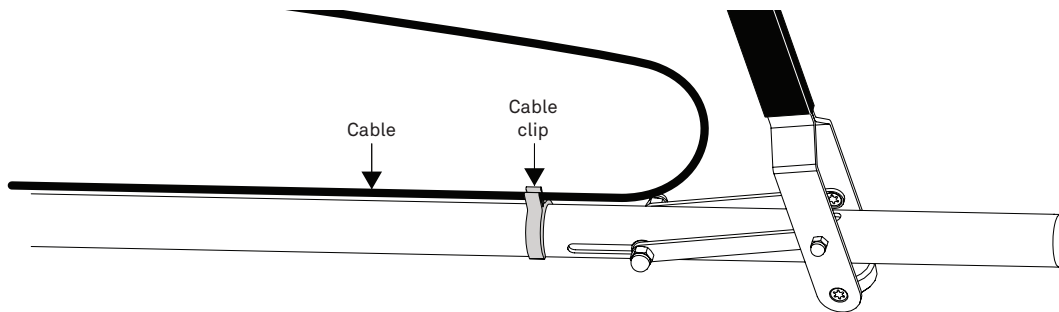

Figure 26 Cable clip on handle

5. Move the handle lever to the vertical position.

This retracts the carrier mount to secure the sensor in preparation to insert the TEROS BIT into the borehole.

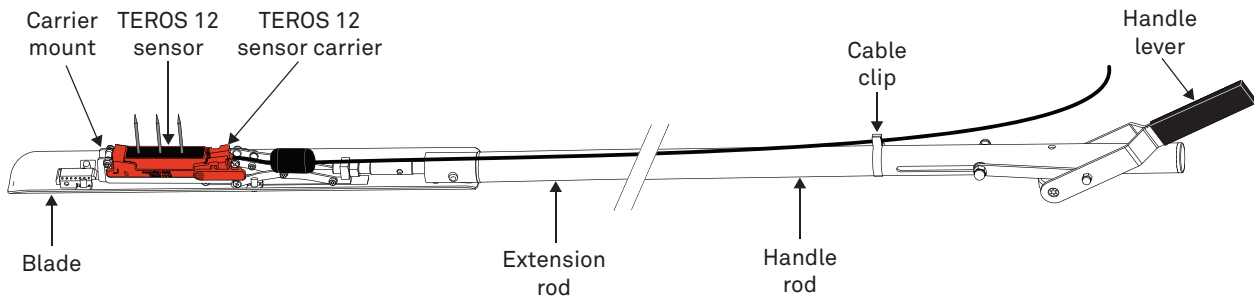

Figure 27 Handle lever in vertical position to retract carrier mount

4.2.6 [REQUIRED] INSERT TEROS BIT INTO BOREHOLE

Make sure the TEROS BIT is pushed back against the borehole and is vertically straight. Be careful not to bump the TEROS 21 against the front edge of the borehole.

1. Use the same flange hole marked in Section 4.2.1.
2. Set the depth selection clamp onto the flange hole marked in Section 4.2.1.
3. Firmly and slowly move the handle lever down into the prepared slot until the handle lever is in the install position (Section 4.2.1).
4. Firmly and slowly move the handle lever up into the retracted position before removing the TEROS BIT from the borehole..
When the handle lever is raised to the retracted position, the two tabs on the sensor carrier retracts, releasing the sensor from the carrier.
5. Make sure the TEROS 21 remains in the borehole sidewall before removing the TEROS BIT from the borehole by using a flashlight or the optional mounted flashlight.
If the TEROS 21 sensor falls out, reapply slurry, place it back in the carrier, and repeat Section 4.2.5.

6. Unhook the sensor cable from the cable clip.
7. Gently pull the TEROS BIT out of the borehole.
If installing sensors in loose soils, it may be necessary to stand on or somehow secure the flange to keep it from moving as the TEROS BIT is removed.

⚠ CAUTION

Be aware of the sensor cable position while removing the TEROS BIT to prevent removing the sensor accidentally.

5. BACKFILL SOIL INTO BOREHOLE

Backfill the soil according to its profile and horizons (i.e., deepest soil removed should be replaced first).

1. Remove the blade and extension rod from the handle rod.
2. Connect the soil tamper tool to the TEROS BIT
 - a. Press down on the handle rod connector buttons.
 - b. Push the soil tamper tool onto the handle rod until seated properly.

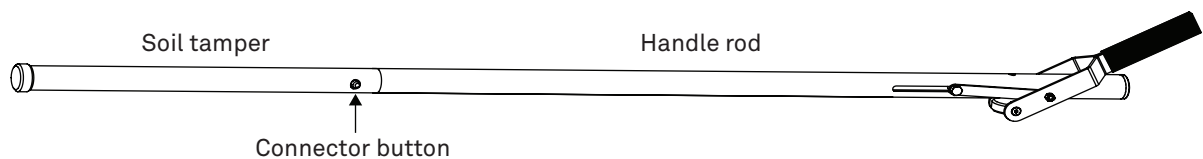

Figure 28 Assemble soil tamper tool

3. Put a small amount of soil from the tarp/plastic into the borehole, respecting the order of soil horizons as placed on the tarp.
4. Carefully insert the TEROS BIT with the soil tamper tool attached into the borehole and evenly compact the soil.

NOTE: It is important to compact the soil to its original density. Otherwise a preferential flow situation may be created and soil compaction may cause stress on the cables.

⚠ CAUTION

Be aware of the sensors and cables while repacking soil to prevent accidental sensor removal when tamping.

5. Repeat [step 3](#) and [step 4](#) until the soil surface is reached.
6. Install cables in conduit when near the ground to avoid rodent damage.
Refer to corresponding METER sensor and ZL6 user manual (meter.ly/manual-downloads) for cable management instructions.

6. SPECIFICATIONS

Dimensions			
Canvas Bag		Blade	
Length	120.00 cm (47.24 in)	Length	50.0 cm (19.7 in)
Width	15.00 cm (5.91 in)	Material	Stainless steel
Height	15.00 cm (5.91 in)	Handle Rod	
Auger		Length	106.00 cm (41.73 in)
Brand	Eijkelkamp	Diameter	35 mm (13.78 in)
Handle and head	0.6 m (1.97 ft)	Extension Outer Rod	
Diameter	100.00 mm (3.94 in)	Length	106.00 cm (41.73 in)
Extension	1.00 m (3.28 ft) (makes a total of 2 m long)	Diameter	35 mm (13.78 in)
		Extension Inner Rod	
		Length	103.00 cm (40.55 in)
		Diameter	14 mm (0.55 in)

Flange	
Diameter, inner	100.00 mm (3.94 in)
Weight	
Assembled	9.00 kg (19.84 lb)

Camera Specifications (not included)

NOTE: The camera listed below is NOT included with the TEROS BIT. Use the information below to search for an ABOCAM model no. Q18 to purchase if desired.

The camera may be used to verify proper sensor installation.

Manufacturer ABOCAM

Modell no. Q18

7. CUSTOMER SUPPORT

NORTH AMERICA

Customer service representatives are available for questions, problems, or feedback Monday through Friday, 7:00 am to 5:00 pm Pacific time.

Email: support.environment@metergroup.com
 sales.environment@metergroup.com

Phone: +1.509.332.5600

Fax: +1.509.332.5158

Website: metergroup.com

EUROPE

Customer service representatives are available for questions, problems, or feedback Monday through Friday, 8:00 to 17:00 Central European time.

Email: support.europe@metergroup.com
 sales.europe@metergroup.com

Phone: +49 89 12 66 52 0

Fax: +49 89 12 66 52 20

Website: metergroup.de

If contacting METER by email, please include the following information:

Name	Email address
Address	Instrument serial number
Phone	Description of the problem

NOTE: For products purchased through a distributor, please contact the distributor directly for assistance.

8. TERMS AND CONDITIONS

By using METER instruments and documentation, you agree to abide by the METER Group, Inc. Terms and Conditions. Please refer to metergroup.com/terms-conditions for details.