



ZL6 Cellular Board Replacement

18318-04
2.2024

Replace the ZL6 cellular board if it malfunctions or needs to be upgraded. These step-by-step instructions will explain the replacement process. A #1 Phillips screwdriver and a wooden stick (included) is required for installation.

NOTE: Update the logger firmware to the latest version to ensure the new communication board is fully supported. Using ZENTRA Utility Mobile go to Device Tools and select Update Device Firmware and for ZENTRA Utility go to the Help menu and select Check for Logger Firmware Updates.

ACCESS COMMUNICATION BOARD

CAUTION: Do not disconnect the solar panel wiring.

1. Remove a battery to turn off the ZL6.
2. Press the **TEST** button to clear power in the logger.
3. Remove the four screws from the main board using a Phillips screwdriver.
4. Carefully lift up the main board and rotate over to expose the underside.

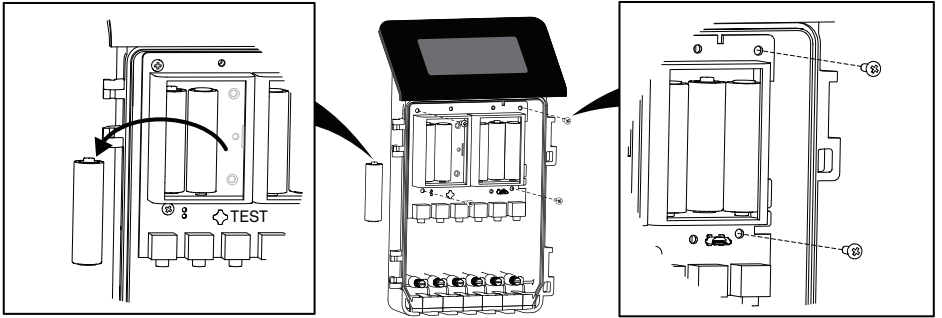

REMOVE EXISTING COMMUNICATION BOARD

NOTE: The appearance of your communication board may vary. Removal is the same even with different versions.

5. Disconnect the antenna cables on the right side of the board by pulling the connector straight out away from the cellular board.
6. Place the wooden stick (included) under the cellular board as shown in the image below.
7. Use the wooden stick to carefully pry the board off the white pegs that hold it on the main board.
8. Place fingers on the outer edge of the board and lift up and off of the remaining pegs.
9. Remove the SIM card if it will be used with the new board.

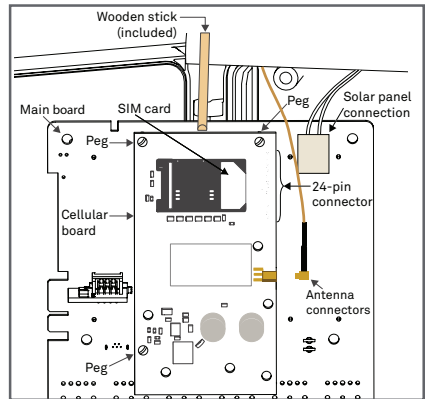

INSERT NEW CELLULAR BOARD

10. Position the new board over the main board and line the corner holes up with the three white pegs.
11. Align the 24-pin connector to ensure none of the pins are bent.
12. Press straight down on the board until the 24-pin connectors audibly click into place.
13. Insert the original (or replacement) SIM into the SIM holder on the new cellular board. Be sure the holder locks into place.

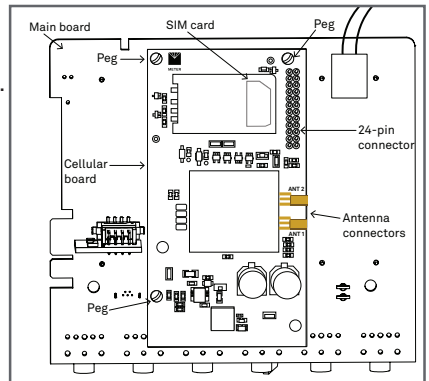

INSTALL SECOND ANTENNA

NOTE: Skip these steps if the kits doesn't contain a second antenna or a second antenna is already installed.

The second antenna is installed on the right side of the enclosure with the cable oriented towards the top of the ZL6.

14. Remove the adhesive backing from the antenna and carefully affix it to the side of the enclosure.
15. Push the cable from the antenna on the right of enclosure into the connector labeled ANT2. Push until a click is heard.

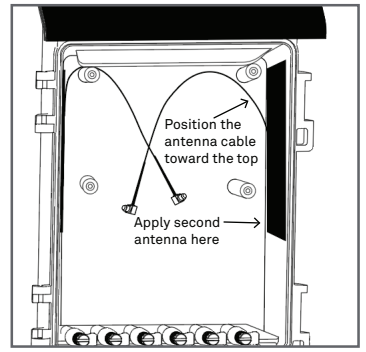

INSTALL AND RETURN MAIN BOARD TO ORIGINAL POSITION

16. Push the cable from the antenna on the right side of the enclosure into the connector on the left side of the cellular board.

Push until a click is heard. Use connector labeled ANT1 if there are two connectors.

17. Carefully lift the main board up and rotate over so batteries are visible.

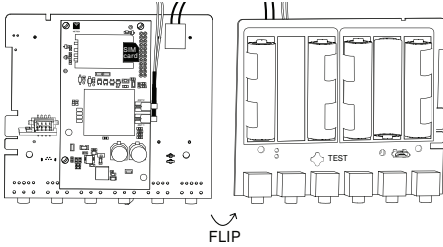

18. Align the board over the mounting posts.

19. Replace the screws.

20. Replace the removed battery.

21. Place new certification label on the inside of the ZL6 case.

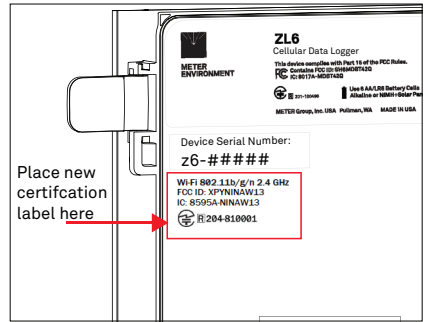

22. Check for ZL6 configuration updates. The new cellular board or SIM may require this ZL6 configuration update to connect.

<https://meter.ly/zl6-modem-swap>



23. Use the **TEST** toolbar button in ZENTRA Utility Mobile or ZENTRA Utility to test the connection to ZENTRA Cloud.

Perform this test at least twice to ensure pending configuration changes from ZENTRA Cloud are successfully received.

If the connection fails, see the ZL6 User Manual (metergroup.com/zl6-support) for communication troubleshooting.