

Davis Cup Anemometer



Decagon Devices, Inc.

Version: April 6, 2015 — 14:15:15

Index

- CE Compliance, 15
- Contact Information, 1
- Declaration of Conformity, 15
- Email, 1
- Seller's Liability, 3
 - Sensor
 - Components, 2
 - Specifications, 4
- Troubleshooting Quick Guide, 13
- Warranty, 2

Decagon Devices, Inc.
2365 NE Hopkins Court
Pullman WA 99163

Phone: 509-332-5600
Fax: 509-332-5158

Website: www.decagon.com

Email: support@decagon.com or sales@decagon.com

Trademarks

©2014 Decagon Devices, Inc.
All Rights Reserved

5 Declaration of Conformity

Application of Council Directive: 2004/108/EC

Standards to which conformity is declared: EN 61326-1:2013

Manufacturer's Name: Davis Instruments Corp. 3465
Diablo Ave. Hayward, California
94545 USA

Type of Equipment: Davis Cup Anemometer

Model Number:

Year of First Manufacture: 2005

This is to certify that the Davis Cup Anemometer, manufactured by Davis Instruments., a corporation based in Hayward, California, USA meets or exceeds the standards for CE compliance as per the Council Directives noted above. This anemometer has been adapted to work with Decagon Devices ECH2O System and is based on the Standard Anemometer manufactured by Davis Instruments. The technical information provided herein is provided courtesy of Davis Instruments®. Please contact Davis Instruments for all pertinent testing documentation.

DAVIS
Davis Instruments

Contents

1 Introduction	1
1.1 Shipping Contents	1
1.2 Warranty	2
1.3 Seller's Liability	3
2 About the Davis Cup Anemometer	4
2.1 Specifications	4
2.2 Integration with Em50	4
2.3 Assembling the Anemometer	5
3 Anemometer Installation	8
3.1 Mounting the Anemometer	8
4 Troubleshooting	13
4.1 Troubleshooting	13
5 Declaration of Conformity	15

1 Introduction

Thank you for choosing the Davis Cup Anemometer wind sensor.

This manual can help you understand the sensor features and ensure successful operation. We hope you find the contents of this manual useful in understanding your instrument and maximizing its benefit to you.

There are several ways to contact Decagon if you ever need assistance with your product, have any questions or feedback. Decagon has Customer Service Representatives available to speak with you Monday through Friday, between 7am and 5pm Pacific time.

Note: If you purchased your sensor through a distributor, please contact them for assistance.

Email:
support@decagon.com or **sales@decagon.com**

Phone:
509-332-5600

Fax:
509-332-5158

If contacting us by email or fax, please include as part of your message your instrument serial number, your name, address, phone, fax number, and a description of your problem or question. Please read these instructions before operating your sensor to ensure that it performs to its full potential.

1.1 Shipping Contents

- Anemometer Arm with Cable
- Anemometer Base
- Wind Cups
- Wind Vane
- Drip Rings

Try dropping the wind cups approximately 1/16" to 1/8" (1.5 to 3 mm) lower on the mounting shaft. Use the included Allen wrench to loosen and tighten the wind cup assembly.

If you still do not get a reading, the problem is with the anemometer. Contact Decagon Devices for return authorization.

Problem 2

Wind speed reading seems too high or low.

Solutions

Check installation by spinning wind cups. If the wind cups spin freely and the weather station displays a wind speed, the wind cups are installed correctly. If the wind cups do not spin freely, then try dropping the wind cups approximately 1/16" to 1/8" (1.5 to 3 mm).

Check for any obstructions blocking the wind near the anemometer.

Problem 3

The wind direction data always reports 0 (North) whenever the wind speed is zero, even if the wind vane is pointing a different direction.

Solutions

The Em50 uses wind speed and direction to calculate the dominant wind direction (See page 2.2). Because this calculation uses vector math, reported wind direction is zero when there is no wind speed.

4 Troubleshooting

Your anemometer does not require any regular maintenance. Do not attempt to lubricate the wind cup shaft and bearings or the wind vane shaft. Natural or synthetic lubricants will inhibit the normal operation of the anemometer.

4.1 Troubleshooting

While your anemometer is designed to provide years of trouble-free operation, occasionally problems may arise. If you are having a problem with your unit, please check the following troubleshooting procedures before sending the unit in for repair. You will be able to solve many of the problems yourself. If, after checking these procedures you are unable to solve the problem, please call Decagon Devices for further instructions (see next section on "Customer Support") Please do not return your unit for repair without receiving prior authorization from Decagon Devices.

If this problem occurs:	Refer to:
Wind speed reads 0 or wind direction "*" * *	Problem #1
Wind speed reading seems too high or low	Problem #2
Reports 0 (North) direction when wind speed 0	Problem #3

Problem 1

Wind speed reads 0 all the time or wind direction is showing "*" * "*" in data field.

Solutions

Make sure anemometer is plugged into port on Em50 or Em50R. Check for broken wire along length of anemometer cable. Carefully check areas where the cable has been secured.

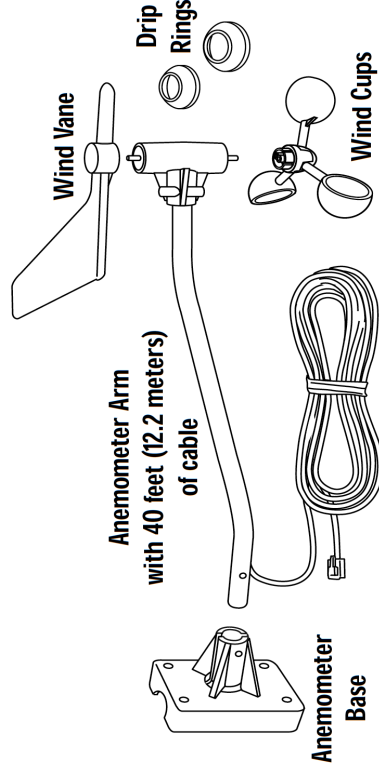

Figure 1: Davis Cup Anemometer Components

Installation Hardware Kit

- Two U-Bolts
- Four 1/4" Flat washers
- Four 1/4" Hex Nuts
- Four 1/4" x 3" Lag Screws
- One #4 - 40 x 1 1/4" Pan Head Screw
- One #4 Flat Washer
- One #9 Lock Washer
- One #4 - 40 Hex Nut
- 0.05" Allen Wrench

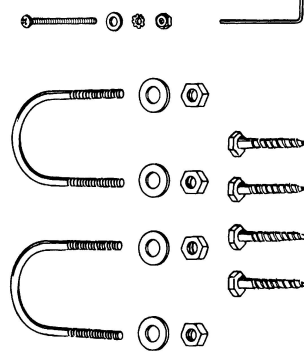

Figure 2: Hardware kit

Note: If any of the components are missing, contact Decagon Devices about receiving replacement items.

1.2 Warranty

The sensor has a 30-day satisfaction guarantee and a one-year warranty on parts and labor. Your warranty automatically validates upon receipt of the instrument.

1.3 Seller's Liability

Seller warrants new equipment of its own manufacture against defective workmanship and materials for a period of one year from the date of receipt of equipment.

Note: We do not consider the results of ordinary wear and tear, neglect, misuse, accident as defects.

The Seller's liability for defective parts shall in no event exceed the furnishing of replacement parts "freight on board" the factory where originally manufactured. Material and equipment covered hereby which is not manufactured by Seller shall be covered only by the warranty of its manufacturer. Seller shall not be liable to Buyer for loss, damage or injuries to persons (including death), or to property or things of whatsoever kind (including, but not without limitation, loss of anticipated profits), occasioned by or arising out of the installation, operation, use, misuse, nonuse, repair, or replacement of said material and equipment, or out of the use of any method or process for which the same may be employed. The use of this equipment constitutes Buyer's acceptance of the terms set forth in this warranty. There are no understandings, representations, or warranties of any kind, express, implied, statutory or otherwise (including, but without limitation, the implied warranties of merchantability and fitness for a particular purpose), not expressly set forth herein.

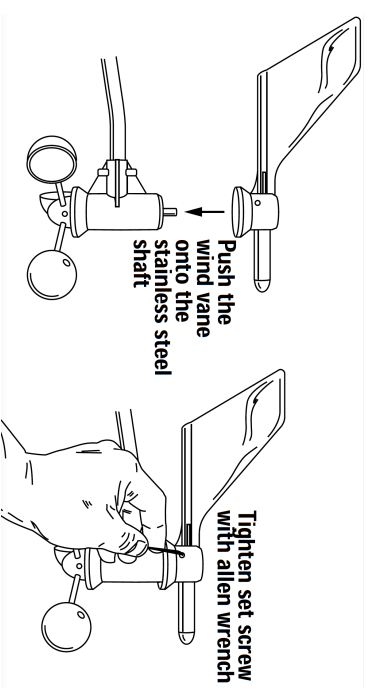

Figure 8: Installing Wind Vane

Securing the Cable

To prevent fraying or cutting the anemometer cable where it is exposed to weather, it is very important to secure it so it does not whip about in the wind. Use cable clips or weather resistant cable ties to secure the cable.

Place clips or ties approximately every 3 to 5 feet (1 to 1.6 m).

Note: Do not use metal staples to secure cables. Metal staples can cut the cables.

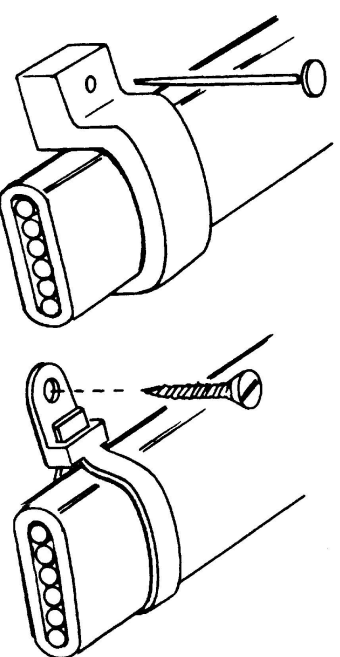

Figure 9: Securing Cable (Standard Cable Shown)

2. Guide the anemometer cable through the slot as you insert the arm.
3. Insert the pan head screw into one of the holes in the base and slide it through the arm.
4. Secure the pan head screw using the flat washer, lock washer, and hex nut as shown.

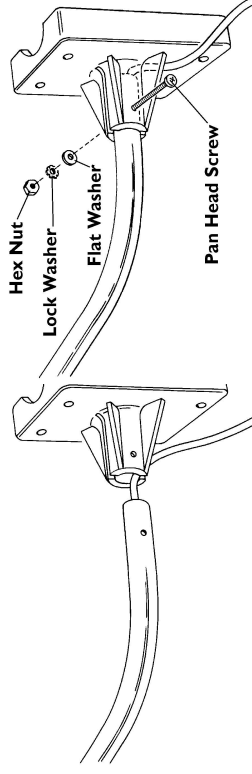

Figure 7: Attaching Anemometer Arm to Base

Attaching the Wind Vane

1. Connect the anemometer cable to the data logger.
2. Align the flat surfaces on the steel shaft and the wind vane.
3. Slide the wind vane down the shaft and use the Allen wrench to tighten the set screw on the side of the wind vane.
4. Press Scan in ECH2O Utility to display wind direction.
5. Use a compass or map to determine true north.
6. Test your assembly by pointing the wind vane in any direction and (using the compass or map as a guide) verify that ECH2O Utility “Scan” displays the correct wind direction.
7. Note the direction of the arm and base for later installation to the pole or mast.
8. Spin the wind cups to make sure you get a wind speed reading and adjust as necessary.

2 About the Davis Cup Anemometer

The anemometer enables you to measure and display wind-related conditions such as wind speed and wind direction with your Em50 or Em50R logger.

2.1 Specifications

- **Wind Direction**

Display Resolution: 16 points (22.5°) on compass rose, 1° in digital display

Accuracy: ±7°

- **Wind Speed**

Range: 2 to 175 mph., 4 to 280 kph, 2 to 152 knots, 0.9 to 78

$\frac{m}{s}$

Accuracy: ±5%

- **System Hardware Compatibility**

Em50 Firmware version 1.19 or greater
ECH2O Utility 1.11 or greater

2.2 Integration with Em50

The Em50 measures the average wind direction in one minute intervals. The value of the wind direction and number of pulse counts (magnitude) are used to resolve the wind direction into X and Y vector components. The vector components from multiple one-minute readings are summed together. The X and Y components are combined to store the “dominant” or “weighted average” wind direction for the measurement interval.

Note: When there is no wind, the vector math for direction will resolve to 0 (North) – regardless of the actual direction of the wind vane.

Speed

The Em50 integrates wind speed pulses for one minute. The highest one-minute count in each measurement interval becomes the value for the gusts data. The average of the one-minute counts becomes the average speed for each measurement interval.

Components and Hardware

The anemometer includes the components listed in the shipping contents. Please be sure you have all listed components before beginning installation. The installation hardware kit contains the items most commonly needed for the installation of the anemometer. Which items you use from the kit depend on where you install your unit. Assess your installation and make sure you have all necessary parts, tools, and materials before you begin. You may need to adapt or purchase additional hardware to fit your individual requirements.

Tools and Materials Needed

You need the following additional tools and materials to install your anemometer. (Not Included)

- Cable Clips or Weather-Resistant Cable Ties

Make sure the clips or ties you use to secure the anemometer cable have screw holes or other means for mounting the cable. Do not use metal staples to secure the cables.

- Stainless Steel Hose Clamps
- Small Screwdrivers
- Adjustable Wrench
- Handheld Compass or Local Area Map

2.3 Assembling the Anemometer

Attaching the Wind Cups

1. Before installing the anemometer, attach the wind cups.

Installing on Antenna Mast or Metal Pipe

1. U-bolts work best with an antenna mast or pipe with outside diameter of 7/8" to 1 1/4" (22 to 32 mm).
2. Hold the anemometer base against the pipe and insert the two U-bolts through the back of the base so that the U-bolts wrap around the pipe.
3. Place a 1/4" washer and a 1/4" 20 hex nut over each end of the U-bolts and use a wrench to tighten the hex nuts.

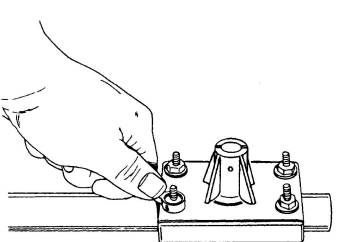
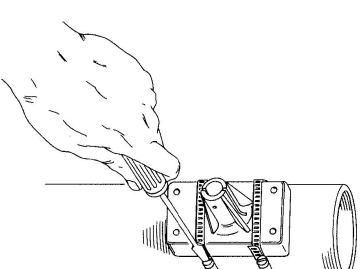

Figure 5: Attaching Base to a Pipe with U-bolts

Installing the Base on a Metal Mast or Pipe:

Outside Diameter Greater than 1 and 1/4" in. (32 mm)

1. Use two stainless steel hose clamps to attach the mounting base to masts or pipes larger than 1 1/4" diameter, large enough to fit around the mast or pipe and the anemometer base. You may purchase hose clamps at your local hardware store.
2. Hold the anemometer base against the pipe and fasten the hose clamps over the anemometer base and Base to a Pipe with around the metal mast or pipe. Hose Clamps



Attaching Arm to Base

1. Insert the anemometer arm into the anemometer base.

or flat surface.

6. Make sure the antenna mast or metal pipe is properly grounded, you may want to use the Davis Grounding Kit.
7. If you are not certain about how to ground your installation, consult a qualified professional for national and local codes.

Note: If you use the Davis Cup Anemometer in an area subject to frequent thunderstorms, install a lightning rod nearby to reduce the risk of damage.

Installing the Base on a Wooden Post or Surface

1. Hold the anemometer base against the wood surface and use a pencil to mark the location of the four holes on the base.
2. Use a drill with a 3/16" (5-mm) drill bit to make pilot holes in these locations.
3. Drive the lag screws through the holes in the anemometer base and into the wood.

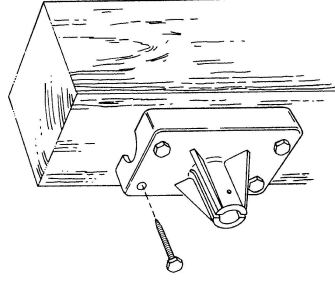

Figure 4: Attaching Base to a Wooden Post

2. Push the wind cups onto the smaller of the two stainless steel shafts.

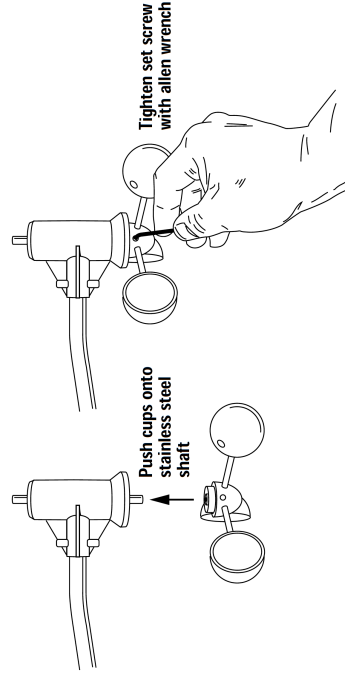

Figure 3: Attaching wind Cups to the Anemometer

3. Slide the wind cups as far up the shaft as possible.
4. Use the Allen wrench provided to tighten the set screw on the side of the wind cups to approximately finger tight.
5. Spin the wind cups. If they do not spin freely, loosen the set screw, lower the cups slightly, then tighten the set screw.
6. Repeat Step 4 until the wind cups spin freely.

Note: The wind vane installation is affected by the direction of the mounting arm. Wind vane direction will be modified during the anemometer installation.

Testing the Anemometer

Before beginning your installation, follow these instructions to test wind speed and wind direction functionality. You will need ECH2O Utility or ECH2O Utility Mobile connected to an Em50 logger.

1. Connect anemometer cable to a port in a Em50 logger.
2. In the sensor pull-down menu for the chosen port in ECH2O Utility, pick "Davis Cup Anemometer"
3. Enter your measurement interval.

4. Spin the wind cups.
5. Scan ports of the logger with ECH2O Utility. You should see revolutions and direction.
6. Note the direction reading of the anemometer.
7. Grab the wind vane and twist about half a turn.
8. Scan ports, reading should have changed about 180 degrees.
9. Disconnect the cables when you are finished testing the anemometer.

3 Anemometer Installation

Choosing the Best Location

Use the following guidelines to determine the best location for your anemometer.

1. Install the anemometer in a location where wind flow is unobstructed by trees and nearby buildings. For instance, mount the anemometer to an antenna mast, wooden post, or metal pipe.
2. For the most accurate readings, mount the anemometer at least 4 feet (1.2 m) above any obstructions.

3.1 Mounting the Anemometer

Use the following procedures to mount the anemometer.

Check the Base Orientation

You will need to know which way to orient the base before installing it.

1. Insert the anemometer arm into the base.
2. Push the #4-40 x 1 1/4" pan head screw through the holes in the arm and the base.
3. Attach the wind vane as previously instructed and press Scan in ECH2O Utility to display wind direction.
4. Use a compass or map to determine true north.
5. Notate the correct base orientation before securing the base to the mast.

Note: it is best to mount the base on a cylindrical mast for easy adjustment of the base orientation. It may not be possible to adjust the base to the correct orientation on a square mast